

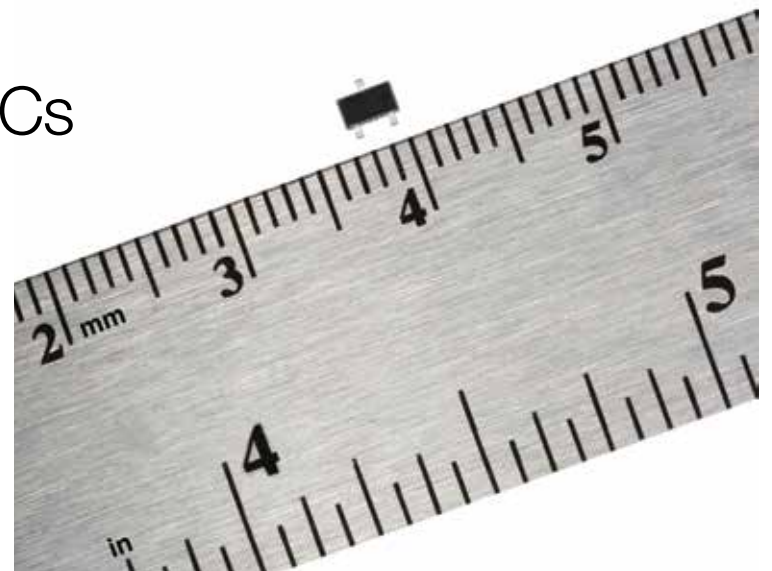

Magneto-resistive Sensor ICs Nanopower Series



Magnetoresistive Sensor ICs

Honeywell's Nanopower Series Magnetoresistive (MR) Sensor ICs are ultra-sensitive devices designed to accommodate a wide range of applications with large air gaps, small magnetic fields and low power requirements.

The sensor ICs respond to either a North or South pole applied in a direction parallel to the sensor. They do not require the magnet polarity to be identified, simplifying installation and potentially reducing system cost.

These sensor ICs use a very low average current consumption and a push-pull output which does not require a pull-up resistor. The sensor ICs can operate from a supply voltage as low as 1.65 V, promoting energy efficiency.

The Nanopower Series is available in two magnetic sensitivities to accommodate a variety of application needs:

- **SM351LT:** For applications requiring ultra high magnetic sensitivity (7 G typical operate, 11 G maximum operate) and a very low current draw (360 nA typical).
- **SM353LT:** For applications requiring very high magnetic sensitivity (14 G typical operate, 20 G maximum operate) and a very low current draw (310 nA typical).

These Magnetoresistive Sensor ICs, Nanopower Series, are supplied in the subminiature SOT-23 surface mount package on tape and reel (3000 units per reel), for use in automated pick-and-place component installation.

Key Features

- **High sensitivity:** 7 Gauss typ., 11 Gauss max. (SM351LT); 14 G typ., 20 Gauss max. (SM353LT)
- **Nanopower:** Average current of 360 nA typ. (SM351LT) and 310 nA typ. (SM353LT)
- **Supply voltage range:** 1.65 Vdc to 5.5 Vdc; simplifies design-in
- **Omnipolar sensing:** Activates with either pole from a magnet
- **Temperature range:** -40 °C to 85 °C [-40 °F to 185 °F]
- **Push-pull output:** Does not require external pull-up resistor
- **Non-chopper stabilized design**
- **RoHS-compliant materials:** Meets Directive 2002/95/EC
- **Package:** SOT-23

Potential Applications

INDUSTRIAL

- Mobile equipment (i.e., handheld computing equipment, scanners)
- Water, electric and gas utility meters
- Building access control; reed switch replacement for battery-operated security systems
- Industrial smoke detectors

MEDICAL

- Exercise equipment
- Infusion pumps
- Drawer position sensing (e.g., medical cabinets)
- Hospital beds

WHITE GOODS

- Lid, door and drawer position detection
- Fluid flow

MEDIUM-SIZED CONSUMER ELECTRONICS

- Battery-optimization position sensor

Magnetoresistive Sensor ICs, Nanopower Series

Table 1A. Electrical Specifications (Vs = 1.65 V to 5.5 V, Ta = -40 °C to 85 °C [-40 °F to 185 °F], Typ. at 1.8 V, 25 °C [77 °F] unless otherwise specified.)

Characteristic	Condition	Min.	Typ.	Max.	Unit
Supply voltage (Vs)	Vs reference to ground	1.65	1.8	5.5	V
Awake current: SM351LT SM353LT	—	— 0.3	1 0.8	5 5	mA
Awake time	—	—	15	—	µs
Sleep current	—	—	0.2	8	µA
	Vs = 1.65 V	—	0.16	0.8	
	Vs = 1.8 V	—	0.2	1	
	Vs = 5.5 Vdc	—	2.6	8	
Sleep time	—	30	100	180	ms
Average current: SM351LT SM353LT	0.015% duty cycle, typ.	— —	360 310	6640 6350	nA
Output voltage: low (V _{OL}) high (V _{OH})	load current = 100 µA	0 Vs - 0.15	0.03 Vs - 0.03	0.15 Vs	V

Table 1B. Electrical Specifications (Vs = 1.8 V, Ta = 25 °C [77 °F].)

Characteristic	Condition	Min.	Typ.	Max.	Unit
Awake current: SM351LT SM353LT	—	— —	1 0.8	1.12 0.87	mA
Awake time	—	—	15	—	µs
Sleep current	—	—	0.2	0.59	µA
Sleep time	—	90	100	120	ms
Average current: SM351LT SM353LT	0.015% duty cycle, typ.	— —	350 350	620 600	nA

Magnetostrictive Sensor ICs, Nanopower Series

Table 2. Magnetic Specifications (Vs = 1.65 V to 5.5 V, Ta = -40 °C to 85 °C [-40 °F to 185 °F].)

Characteristic	Min.	Typ.	Max.	Unit
SM351LT:				
operate (positive)	3	7	11	Gauss
release (positive)	2	5	—	
hysteresis	*	2	—	
SM353LT:				
operate (positive)	6	14	20	Gauss
release (positive)	3	10	—	
hysteresis	*	4	—	

*At 1.65 V and -40 °C, the hysteresis can reach 0.1 Gauss.

NOTICE

The magnetic field strength (Gauss) required to cause the switch to change state (operate and release) will be as specified in the magnetic characteristics. To test the switch against the specified magnetic characteristics, the switch must be placed in a uniform magnetic field.

NOTICE

These magnetostrictive sensor ICs may have an initial output in either the ON or OFF state if powered up with an applied magnetic field in the differential zone (applied magnetic field >Brp and <Bop). Honeywell recommends allowing 10 μs for output voltage to stabilize after supply voltage has reached its final rated value.

Table 3. Absolute Maximum Ratings

Characteristic	Condition	Min.	Typ.	Max.	Unit
Operating temperature	ambient	-40 [-40]	—	85 [185]	°C [°F]
Soldering temperature	ambient applied for <10 s	—	—	265 [509]	°C [°F]
Supply voltage (Vs)	—	-0.5	—	5.5	V
Output (load) current	—	—	100	150	μA

NOTICE

Absolute maximum ratings are the extreme limits that the device will withstand without damage to the device. However, the electrical and mechanical characteristics are not guaranteed as the maximum limits (above recommended operating conditions) are approached, nor will the device necessarily operate at absolute maximum ratings.



Figure 1. Block/Electrical Diagram

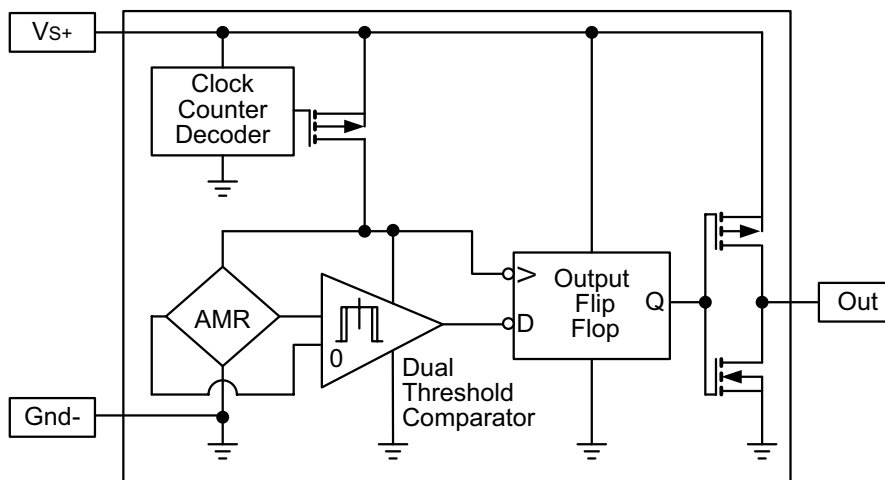

Magneto-resistive Sensor ICs, Nanopower Series

Figure 2. SM351LT Typical Performance Characteristics

Magnetic Performance vs Temperature ($V_s = 1.8\text{ V}$)

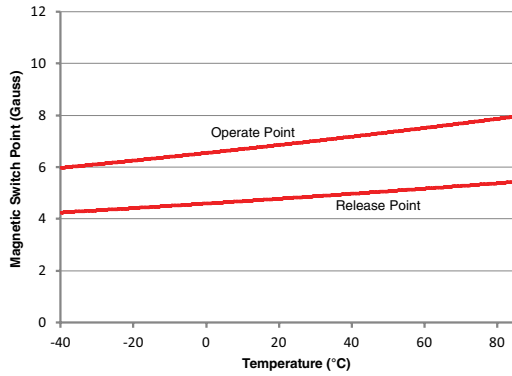

Period vs Temperature

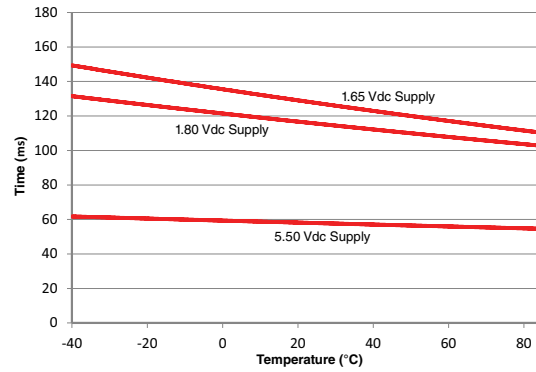

Average Current vs Temperature

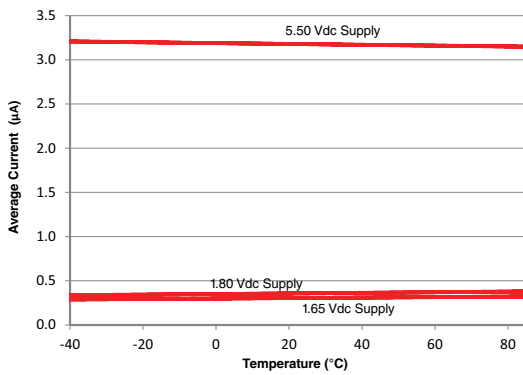

Active Mode Time vs Temperature

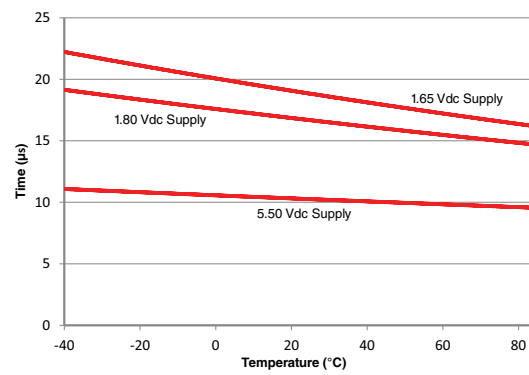
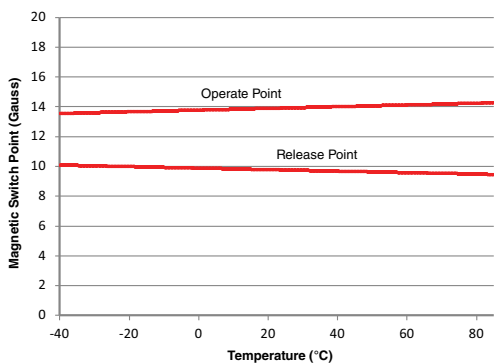
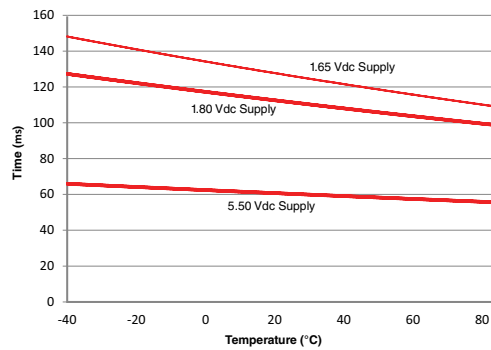

Figure 3. SM353LT Typical Performance Characteristics

Magnetic Performance vs Temperature ($V_s = 1.8\text{ V}$)



Period vs Temperature



Average Current vs Temperature

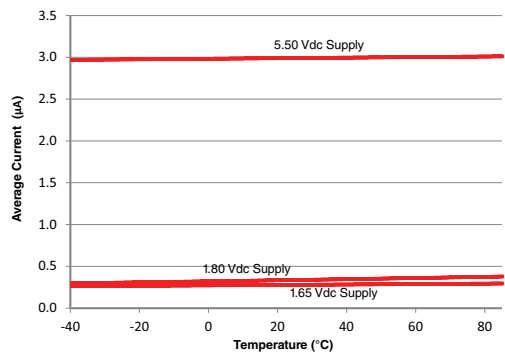

Active Mode Time vs Temperature

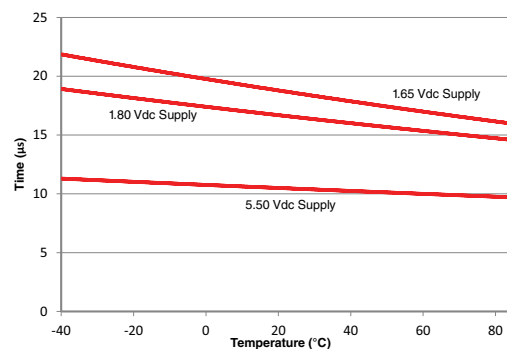

Magneto-resistive Sensor ICs, Nanopower Series

Figure 4. Mounting and Tape/Reel Dimensions (For reference only. mm/[in.])

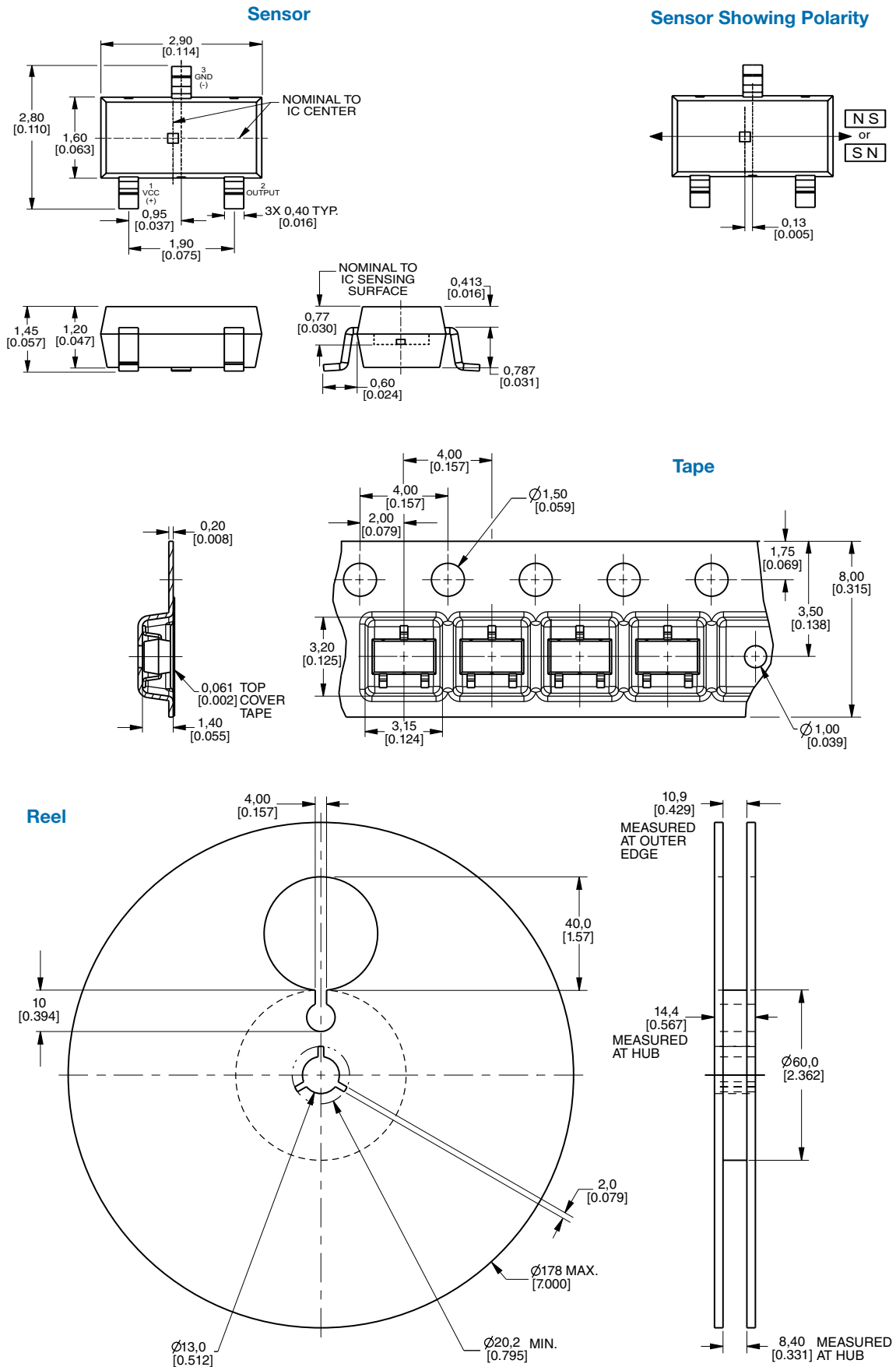

Order Guide

Catalog Listing	Description
SM351LT	Magnetoresistive sensor IC, high sensitivity (7 G typ.), nanopower, SOT-23 package, tape and reel packaging (3000 units per reel)
SM353LT	Magnetoresistive sensor IC, high sensitivity (14 G typ.), nanopower, SOT-23 package, tape and reel packaging (3000 units per reel)

ADDITIONAL INFORMATION

The following associated literature is available at sensing.honeywell.com:

- Product line guide
- Product range guide
- Product installation instructions
- Application note

⚠ WARNING **PERSONAL INJURY**

DO NOT USE these products as safety or emergency stop devices or in any other application where failure of the product could result in personal injury.

Failure to comply with these instructions could result in death or serious injury.

⚠ WARNING **MISUSE OF DOCUMENTATION**

- The information presented in this product sheet is for reference only. Do not use this document as a product installation guide.
- Complete installation, operation, and maintenance information is provided in the instructions supplied with each product.

Failure to comply with these instructions could result in death or serious injury.

Sales and Service

Honeywell serves its customers through a worldwide network of sales offices, representatives and distributors. For application assistance, current specifications, pricing or name of the nearest Authorized Distributor, contact your local sales office or email us at info.sc@honeywell.com. Visit us on the Web at sensing.honeywell.com

Phone and Fax:

Asia Pacific	+65 6355-2828 +65 6445-3033 Fax
Europe	+44 (0) 1698 481481 +44 (0) 1698 481676 Fax
Latin America	+1-305-805-8188 +1-305-883-8257 Fax
USA/Canada	+1-800-537-6945 +1-815-235-6847 +1-815-235-6545 Fax

Sensing and Control
Honeywell
1985 Douglas Drive North
Golden Valley, MN 55422
honeywell.com

WARRANTY/REMEDY

Honeywell warrants goods of its manufacture as being free of defective materials and faulty workmanship. Honeywell's standard product warranty applies unless agreed to otherwise by Honeywell in writing; please refer to your order acknowledgement or consult your local sales office for specific warranty details. If warranted goods are returned to Honeywell during the period of coverage, Honeywell will repair or replace, at its option, without charge those items it finds defective. **The foregoing is buyer's sole remedy and is in lieu of all other warranties, expressed or implied, including those of merchantability and fitness for a particular purpose. In no event shall Honeywell be liable for consequential, special, or indirect damages.**

While we provide application assistance personally, through our literature and the Honeywell website, it is up to the customer to determine the suitability of the product in the application.

Specifications may change without notice. The information we supply is believed to be accurate and reliable as of this printing. However, we assume no responsibility for its use.

Honeywell