

# Bridgelux Micro SM4

## Product Data Sheet DS27

### Introduction

The Bridgelux Micro SM4 delivers high performance, compact and cost-effective solid-state lighting solutions to serve general and specialty lighting applications. These products combine the higher efficacy, lifetime, and reliability benefits of LEDs with the light output levels of low wattage conventional light sources. The Bridgelux Micro SM4 series has been designed to enable a cost-effective design for LED retrofit bulbs, halogen spotlights, consumer luminaires and other general lighting applications.

The Bridgelux Micro SM4 provides a high performance alternative to conventional solid state solutions in 2700K and 3000K warm-white and 5600K cool-white color temperatures. These compact high flux density light sources enable both diffuse and directional lamp replacements for a wide range of applications.

Lighting system designs incorporating these products deliver performance comparable to that of a 20-40 Watt incandescent, 20-35 Watt halogen and low wattage compact fluorescent lamps and luminaires and feature increased system level efficacy and service life. Typical applications include replacement lamps, task lighting, under cabinet, accent, pendant, sconces, porch, pathway, landscape, portable, consumer luminaires and consumer white goods.

### Features

- Compact high flux density light source
- Low thermal resistance and electrically neutral thermal path
- Energy Star / ANSI based 4-step color space with 3-step binning options
- Available in 350mA (12V) and 700mA (6V) versions
- More energy efficient than incandescent, halogen and fluorescent lamps
- Low voltage DC operation
- Instant light with unlimited dimming
- 5-year warranty
- RoHS compliant and Pb free (certification pending)

### Benefits

- Enhanced optical control
- Increased design flexibility and operating temperature range
- Consistent white light
- Enables driver design flexibility and low voltage lighting products
- Lower operating costs
- Increased safety
- Easy to use with daylight and motion detectors to enable increased energy savings
- Reduced maintenance costs
- Environmentally friendly, no disposal issue



---

## Table of Contents

Page

Product Nomenclature .....	3
Average Lumen Maintenance Characteristics .....	3
Environmental Compliance .....	3
UL Recognition.....	4
Minor Product Change Policy.....	4
Cautionary Statements.....	4
Quick Selection Guide.....	5
Flux Characteristics.....	6
Optical Characteristics .....	7
Electrical Characteristics.....	8
Absolute Minimum and Maximum Ratings.....	9
Mechanical Dimensions .....	10
Recommended Solder Pad Dimensions .....	11
Reflow Solder Specifications.....	12
Typical Radiation Pattern .....	13
Wavelength Characteristics at Rated Test Current, $T_j=25^{\circ}\text{C}$ .....	13
Typical Relative Luminous Flux vs. Current, $T_j=25^{\circ}\text{C}$ .....	14
Typical Light Output Characteristics vs. Temperature .....	15
Typical Chromaticity Characteristics vs. Temperature .....	16
Typical Forward Current Characteristics.....	17
Color Binning Information.....	18
Packaging Drawings .....	21
Design Resources .....	22

---

## Product Nomenclature

The part number designation for the Bridgelux Micro SM4 is explained as follows:

BXPX – AB C DEFG – H – JJKK

Where:

BXPX – Designates product family

AB – Designates the nominal ANSI color temperature; 27 = 2700K; 30 = 3000K, etc.

C - Designates minimum CRI; C = 70, E = 80, G = 90

DEFG - Designates Nominal Flux; 0400 = 400lm, 0520 = 500lm, etc.

H – Designates configuration; A = 350mA (12V); B = 700mA (6V)

JJ – Designates color bin options

03 = 3 SDCM

04 = 4 SDCM

KK – Reserved. Default = 00

## Average Lumen Maintenance Characteristics

Bridgelux projects that its Micro SM4 family of products will deliver, on average, greater than 70% lumen maintenance after 50,000 hours of operation at the rated forward test current. This performance assumes constant current operation with solder pad temperature maintained at or below 85°C. For use beyond these typical operating conditions please consult your Bridgelux sales representative for further assistance.

These projections are based on a combination of package test data, semiconductor chip reliability data, a fundamental understanding of package related degradation mechanisms, and performance observed from products installed in the field using Bridgelux die technology. Bridgelux conducts lumen maintenance tests per LM80. Observation of design limits is required in order to achieve this projected lumen maintenance.

## Environmental Compliance

Bridgelux is committed to providing environmentally friendly products to the solid-state lighting market. Bridgelux LEDs are compliant to the European Union directives on the restriction of hazardous substances in electronic equipment, namely the RoHS directive. Bridgelux will not intentionally add the following restricted materials to LED products: lead, mercury, cadmium, hexavalent chromium, polybrominated biphenyls (PBB) or polybrominated diphenyl ethers (PBDE).

---

## UL Recognition

Bridgelux secures UL Recognition for all the LED products. Bridgelux uses UL Recognized materials with suitable flammability ratings to streamline the process for customers to secure UL listing of the final luminaire product (certification pending).

## Minor Product Change Policy

The rigorous qualification testing on products offered by Bridgelux provides performance assurance. Slight cosmetic changes that do not affect form, fit, or function may occur as Bridgelux continues product optimization.

## Cautionary Statements

### CAUTION: CONTACT WITH OPTICAL AREA

Contact with the silicone lens should be avoided. Applying stress to the silicone lens can result in damage to the product.

### CAUTION: EYE SAFETY

Eye safety classification for the use of the Bridgelux Micro SM4 product series is in accordance with IEC – EN62471 Photobiological Safety of Lamps and Lamp Systems specification. These products are classified as Risk Group 1 (Low Risk) when operated at or below the rated test current. Please use appropriate precautions. It is important that employees working with LEDs are trained to use them safely.

### CAUTION: RISK OF BURN

Do not touch the LED during operation. Allow the LED to cool for a sufficient period of time before handling. The LED may reach elevated temperatures such that it can burn skin when touched.

### CAUTION: CHEMICAL EXPOSURE HAZARD

Exposure to some chemicals commonly used in luminaire manufacturing and assembly can cause damage to the LED. Please consult Bridgelux Application Note AN21 for additional information.

## Quick Selection Guide

Table 1: Selection Guide for Bridgelux Micro SM4

Orderable Part Number	CCT (Nominal)	CRI (min)	Typical Pulsed Flux $T_j = 25^\circ\text{C}$ (lm)	Test Current (mA)	Typical Vf (V)	Typical Power Dissipation (W)	Typical Efficacy $T_j = 25^\circ\text{C}$ (lm/W)
BXPX-27E0400-A-0300 BXPX-27E0400-A-0400	2700K	80	380	350	12.2	4.25	89
BXPX-27E0400-B-0300 BXPX-27E0400-B-0400	2700K	80	380	700	6.1	4.25	89
BXPX-27G0400-A-0300 BXPX-27G0400-A-0400	2700K	90	330	350	12.2	4.25	77
BXPX-27G0400-B-0300 BXPX-27G0400-B-0400	2700K	90	330	700	6.1	4.25	77
BXPX-30E0400-A-0300 BXPX-30E0400-A-0400	3000K	80	400	350	12.2	4.25	94
BXPX-30E0400-B-0300 BXPX-30E0400-B-0400	3000K	80	400	700	6.1	4.25	94
BXPX-30G0400-A-0300 BXPX-30G0400-A-0400	3000K	90	360	350	12.2	4.25	84
BXPX-30G0400-B-0300 BXPX-30G0400-B-0400	3000K	90	360	700	6.1	4.25	84
BXPX-56C0520-A-0400	5600K	70	500	350	12.2	4.25	117
BXPX-56C0520-B-0400	5600K	70	500	700	6.1	4.25	117

## Flux Characteristics

Table 2: Flux Characteristics

Color	ANSI CCT	Base Part Number	CRI (min) <sup>(3)</sup>	Typical DC Flux T <sub>J</sub> = 85°C (lm)	Minimum Pulsed Flux T <sub>J</sub> = 25°C (lm) <sup>(1)</sup>	Typical Pulsed Flux T <sub>J</sub> = 25°C (lm)	Test Current (mA) <sup>(2)</sup>
Warm White	2700K	BXPX-27E0400-A-0x00	80	340	340	380	350
		BXPX-27E0400-B-0x00	80	340	340	380	700
		BXPX-27G0400-A-0x00	90	300	300	330	350
		BXPX-27G0400-B-0x00	90	300	300	330	700
	3000K	BXPX-30E0400-A-0x00	80	360	360	400	350
		BXPX-30E0400-B-0x00	80	360	360	400	700
		BXPX-30G0400-A-0x00	90	325	320	360	350
		BXPX-30G0400-B-0x00	90	325	320	360	700
Cool White	5600K	BXPX-56C0520-A-0400	70	450	460	500	350
		BXPX-56C0520-B-0400	70	450	460	500	700

Notes for Table 2:

1. Bridgelux maintains a  $\pm 7\%$  tolerance on flux measurements.
2. Parts are tested in pulsed conditions, T<sub>J</sub> = 25°C. Pulse width is 10 ms at rated test current.
3. Bridgelux maintains a  $\pm 2$  tolerance on CRI measurements. The typical R9 value for 90 CRI minimum emitters is 50.

## Optical Characteristics

Table 3: Optical Characteristics

Color	ANSI CCT	Base Part Number	Typical Color Temperature (CCT) <sup>[1], [2], [3]</sup>	CRI (min)	Typical Viewing Angle (Degrees) $2\theta^{1/2}$ <sup>[4]</sup>
Warm White	2700K	BXPX-27E0400-A-0x00	2725K	80	145
		BXPX-27E0400-B-0x00	2725K	80	145
		BXPX-27G0400-A-0x00	2725K	90	145
		BXPX-27G0400-B-0x00	2725K	90	145
	3000K	BXPX-30E0400-A-0x00	3045K	80	145
		BXPX-30E0400-B-0x00	3045K	80	145
		BXPX-30G0400-A-0x00	3045K	90	145
		BXPX-30G0400-B-0x00	3045K	90	145
Cool White	5600K	BXPX-56C0520-A-0400	5665K	70	145
		BXPX-56C0520-B-0400	5665K	70	145

Notes for Table 3:

1. Parts are tested in pulsed conditions,  $T_j = 25^\circ\text{C}$ . Pulse width is 10 ms at rated test current.
2. Refer to Flux Characteristic Table for test current data.
3. Product is binned for color in x y coordinates.
4. Viewing angle is the off axis angle from the centerline where  $I_v$  is  $\frac{1}{2}$  of the peak value.

## Electrical Characteristics

Table 4: Electrical Characteristics

Color	Base Part Number	Forward Voltage Vf (V) <sup>[2]</sup>			Test Current (mA) <sup>[1]</sup>	Typical Coefficient of Forward Voltage (mV/°C) $\Delta V_f / \Delta T_j$	Typical Thermal Resistance Junction to Solder Point (°C/W) $R\theta_{j-s}$ <sup>[3]</sup>
		Min	Typ	Max			
Warm White	BXPX-27E0400-A-0x00	11.6	12.2	12.6	350	-4 to -12	1.9
	BXPX-27E0400-B-0x00	5.8	6.1	6.3	700	-2 to -6	1.9
	BXPX-27G0400-A-0x00	11.6	12.2	12.6	350	-4 to -12	1.9
	BXPX-27G0400-B-0x00	5.8	6.1	6.3	700	-2 to -6	1.9
	BXPX-30E0400-A-0x00	11.6	12.2	12.6	350	-4 to -12	1.9
	BXPX-30E0400-B-0x00	5.8	6.1	6.3	700	-2 to -6	1.9
	BXPX-30G0400-A-0x00	11.6	12.2	12.6	350	-4 to -12	1.9
	BXPX-30G0400-B-0x00	5.8	6.1	6.3	700	-2 to -6	1.9
Cool White	BXPX-56C0520-A-0400	11.6	12.2	12.6	350	-4 to -12	1.9
	BXPX-56C0520-B-0400	5.8	6.1	6.3	700	-2 to -6	1.9

Notes for Table 4:

1. Parts are tested in pulsed conditions,  $T_j = 25^\circ\text{C}$ . Pulse width is 10 ms at rated test current.
2. Bridgelux maintains a tester tolerance of  $\pm 0.10$  V on forward voltage measurements.
3. Includes solder interconnect layer required to reflow emitter to application PCB.



## Absolute Minimum and Maximum Ratings

Table 5: Maximum Current and Reverse Voltage Ratings

Color	Base Part Number	Maximum DC Forward Current (mA)	Maximum Peak Pulsed Current (mA) <sup>[1]</sup>	Maximum Reverse Voltage (Vr) <sup>[2]</sup>
Warm White	BXPX-27E0400-A-0x00	500	700	-20 V
	BXPX-27E0400-B-0x00	1000	1400	-10 V
	BXPX-27G0400-A-0x00	500	700	-20 V
	BXPX-27G0400-B-0x00	1000	1400	-10 V
	BXPX-30E0400-A-0x00	500	700	-20 V
	BXPX-30E0400-B-0x00	1000	1400	-10 V
	BXPX-30G0400-A-0x00	500	700	-20 V
	BXPX-30G0400-B-0x00	1000	1400	-10 V
Cool White	BXPX-56C0520-A-0400	500	700	-20 V
	BXPX-56C0520-B-0400	1000	1400	-10 V

Notes for Table 5:

1. Bridgelux recommends a maximum duty cycle of 10% when operating LEDs at the maximum peak pulsed current specified.
2. Light emitting diodes are not designed to be driven in reverse voltage.

Table 6: Maximum Ratings

Parameter	Maximum Rating
LED Junction Temperature	150°C
Storage Temperature	-40°C to +135°C
Operating Solder Point Temperature	105°C at rated test current, 85°C at maximum drive current
ESD Classification	Class 2 (HBM per JESD22-A114-F)
Reflow Solderable	JEDEC-J-STD-020C
Moisture Sensitivity Rating	MSL1
Floor Life	Unlimited ≤ 30°C / 85% RH

---

## Mechanical Dimensions

Figure 1: Mechanical Dimensions for Bridgelux Micro SM4

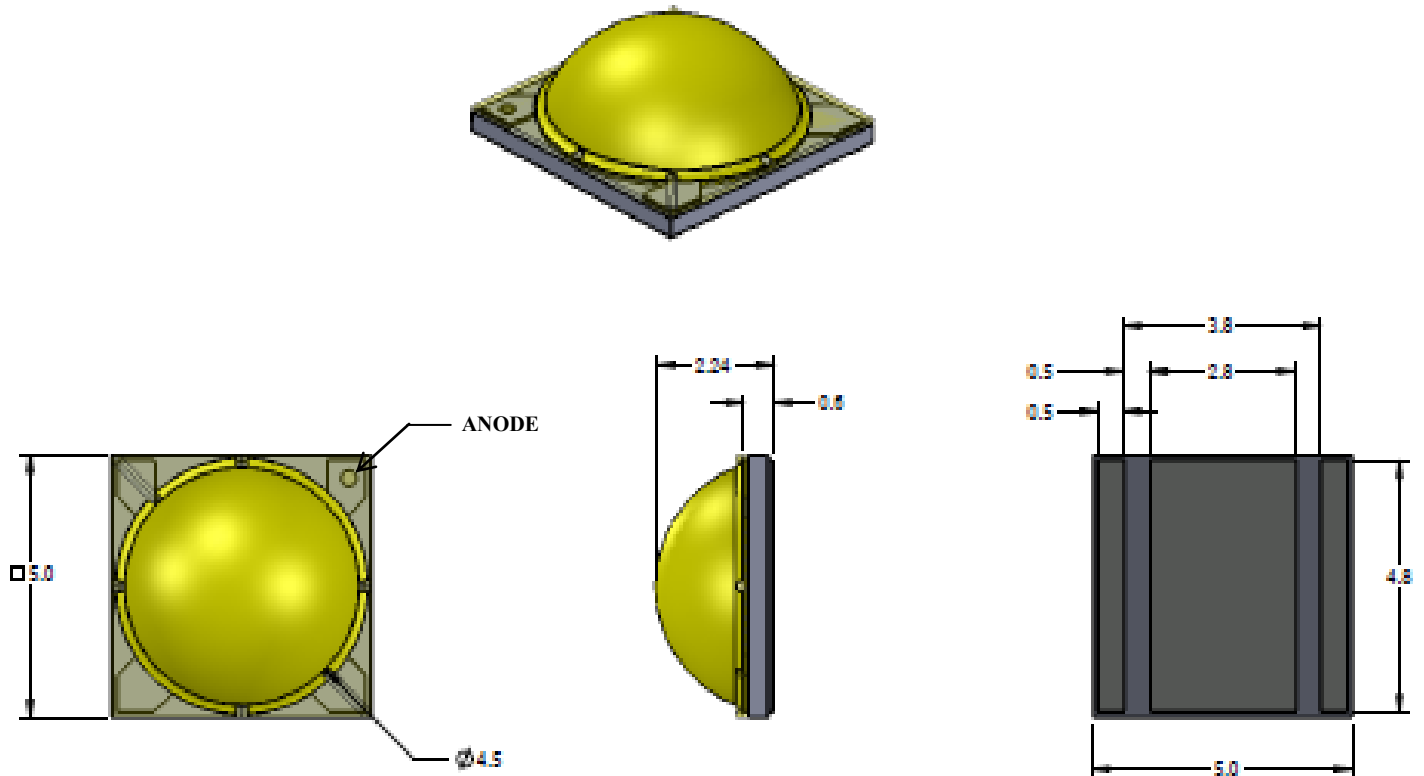

### Notes for Figure 1:

1. Drawing is not to scale.
2. Drawing dimensions are in millimeters.
3. Unless otherwise specified, tolerances are  $\pm 0.20\text{mm}$ .
4. Refer to product Application Notes AN21 for product handling and assembly recommendations.
5. The optical center of the LED is defined by the mechanical center of the product
6. 3D CAD model available at [www.bridgelux.com](http://www.bridgelux.com)

---

## Recommended Solder Pad Dimensions

Figure 2: Recommended Solder Pad Dimensions (Anode, Thermal Pad and Cathode)

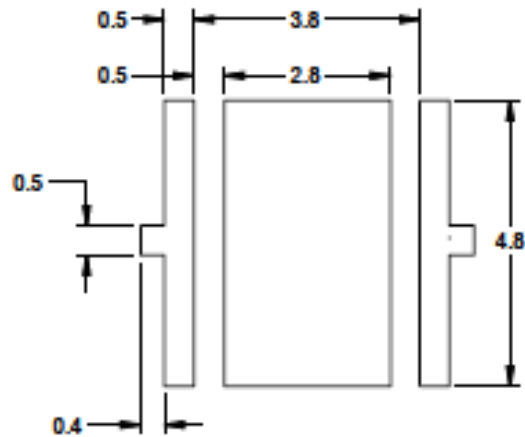

### Notes for Figure 2:

1. Drawing is not to scale.
2. Drawing dimensions are in millimeters.
3. Unless otherwise specified, tolerances are  $\pm 0.20\text{mm}$ .
4. Refer to product Application Notes AN21 for product handling and assembly recommendations.

## Reflow Solder Specifications

The Bridgelux Micro SM4 products are compatible with JEDEC J-STD-020C, following the profile and parameters listed below.

Figure 3: Reflow Solder Profile

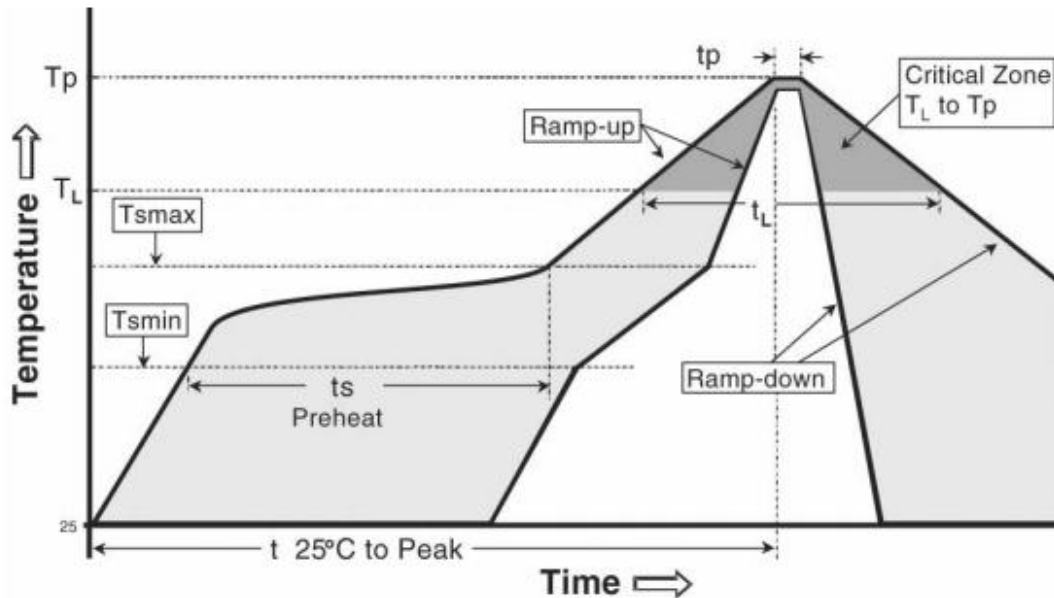

Table 7: Reflow Solder Parameters

Profile Feature	Specification Using Lead Free Solder
Average Ramp-Up Rate (Tsmax to Tp)	3°C / second max
Preheat Temperature Min (Tsmmin)	150°C
Preheat Temperature Max (Tsmax)	200°C
Preheat Time (Tsmmin to Tsmax)	60-180 seconds
Temperature (TL)	217°C
Time Maintained Above Temperature (TL)	60-150 seconds
Peak/Classification Temperature (Tp)	260°C
Time Within 5°C of Actual Peak Temperature (tp)	20-40 seconds
Ramp Down Rate	6°C / second max
Time 25°C to Peak Temperature	8 minutes max

Notes for Figure 2 and Table 7:

1. Recommended reflow profile. Optimization for specific reflow equipment and solder paste should be independently established.

---

## Typical Radiation Pattern

Figure 4: Typical Far Field Radiation Pattern

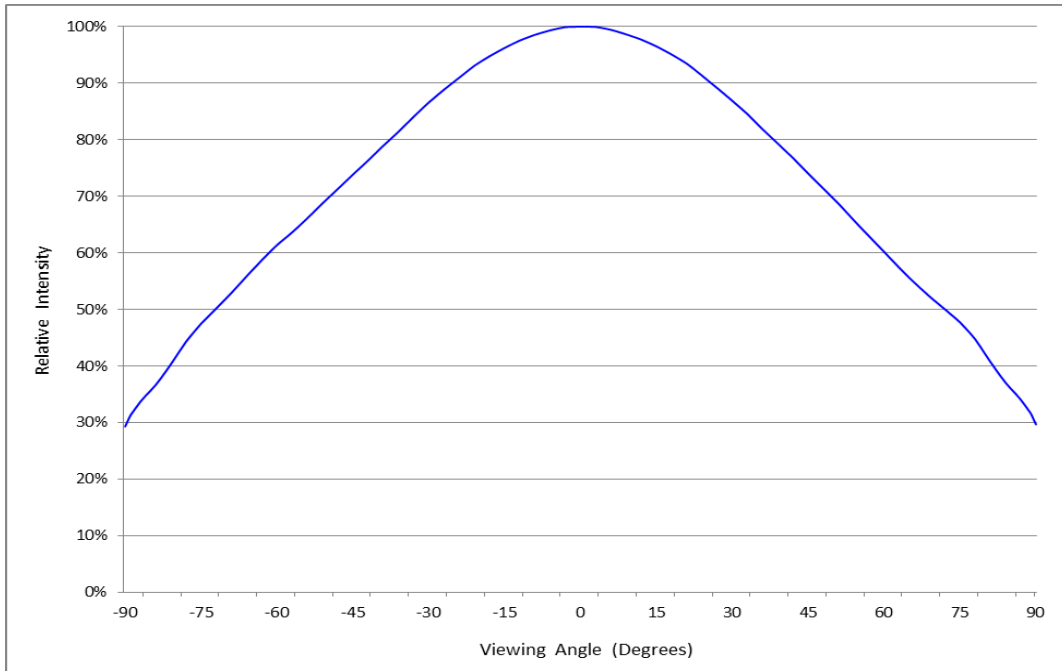

## Wavelength Characteristics at Rated Test Current, $T_j=25^\circ\text{C}$

Figure 5: Typical Warm-White and Cool-White Color Spectrum

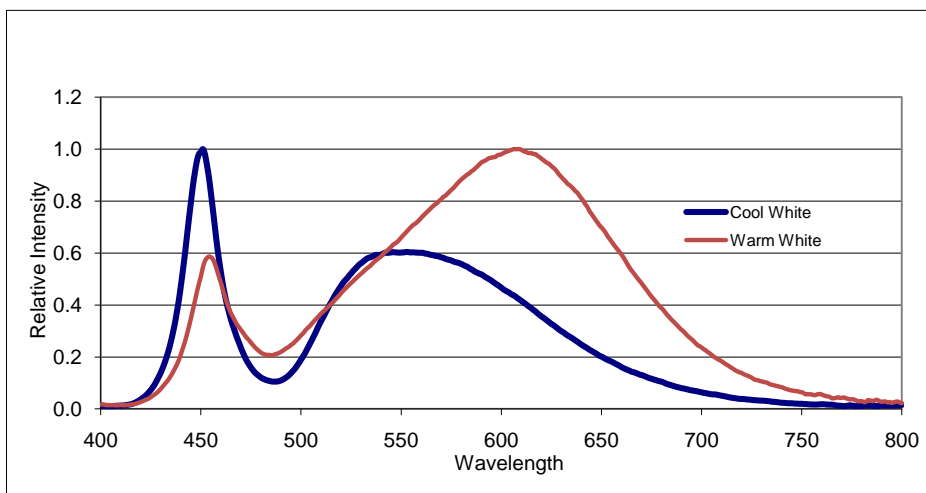

---

## Typical Luminous Flux vs. Current, $T_j=25^\circ\text{C}$

Figure 6: Typical Luminous Flux versus Current  
350mA 12V emitters (BXPX-xxxxxxx-A series products)

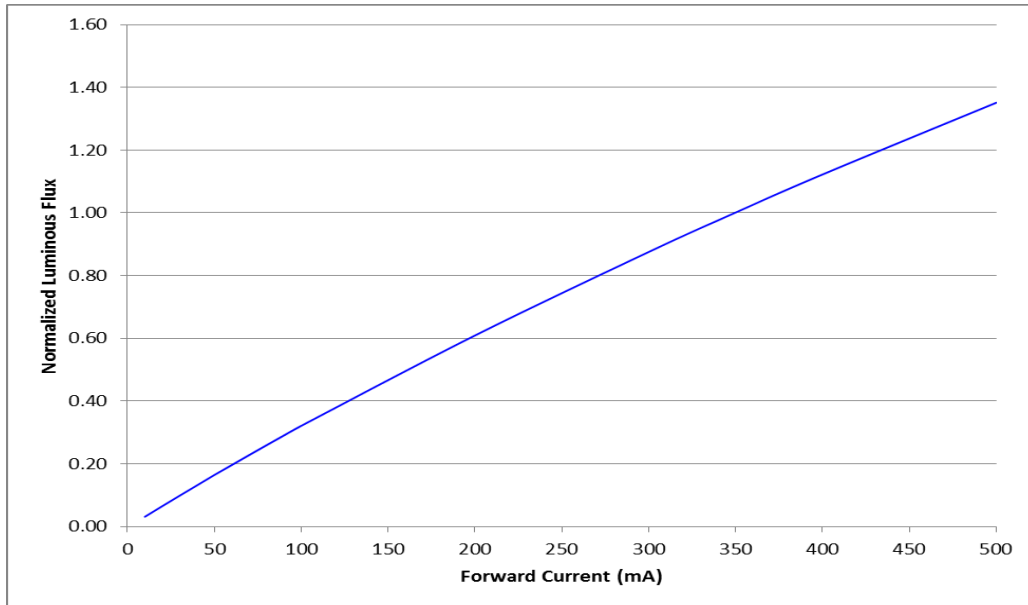
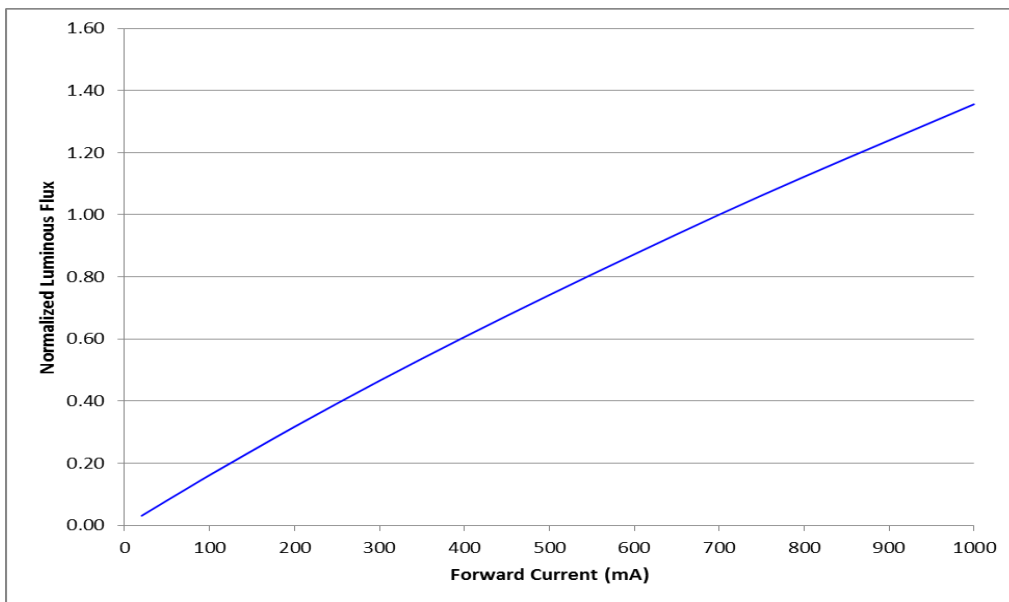

Figure 7: Typical Luminous Flux versus Current  
700mA 6V emitters (BXPX-xxxxxxx-B series products)



---

## Typical Light Output Characteristics vs. Temperature

Figure 8: Typical Flux vs. Junction Temperature

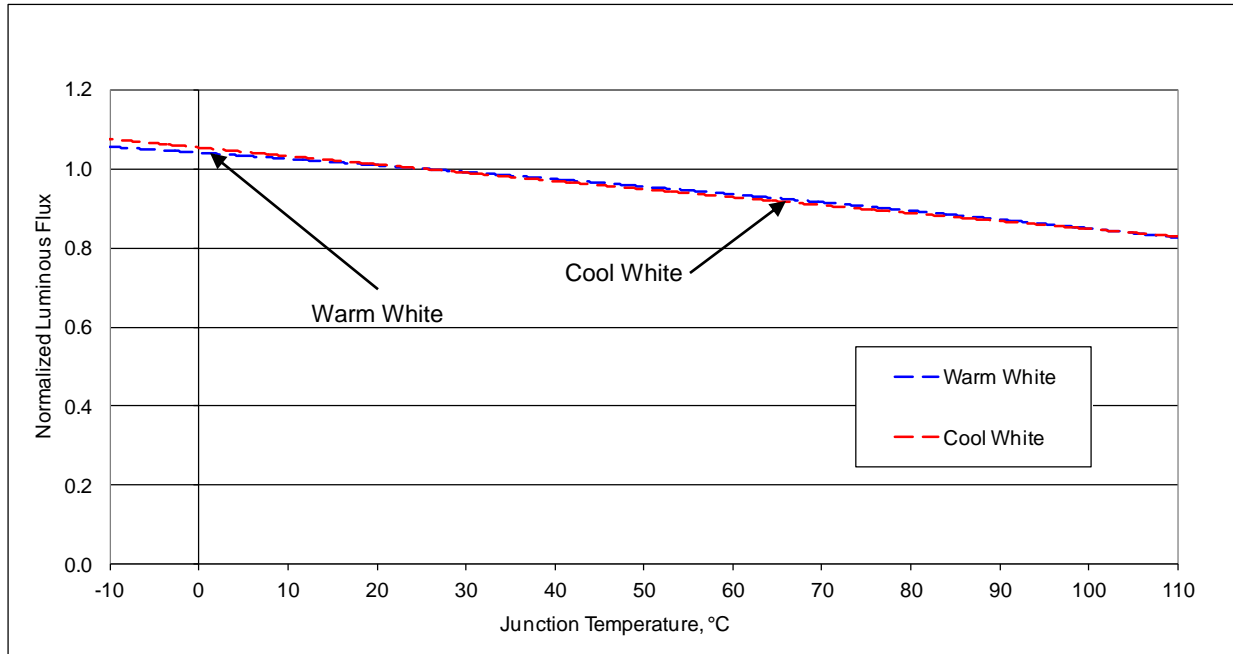

## Typical Chromaticity Characteristics vs. Temperature

Figure 9: Typical ccx Shift vs. Junction Temperature

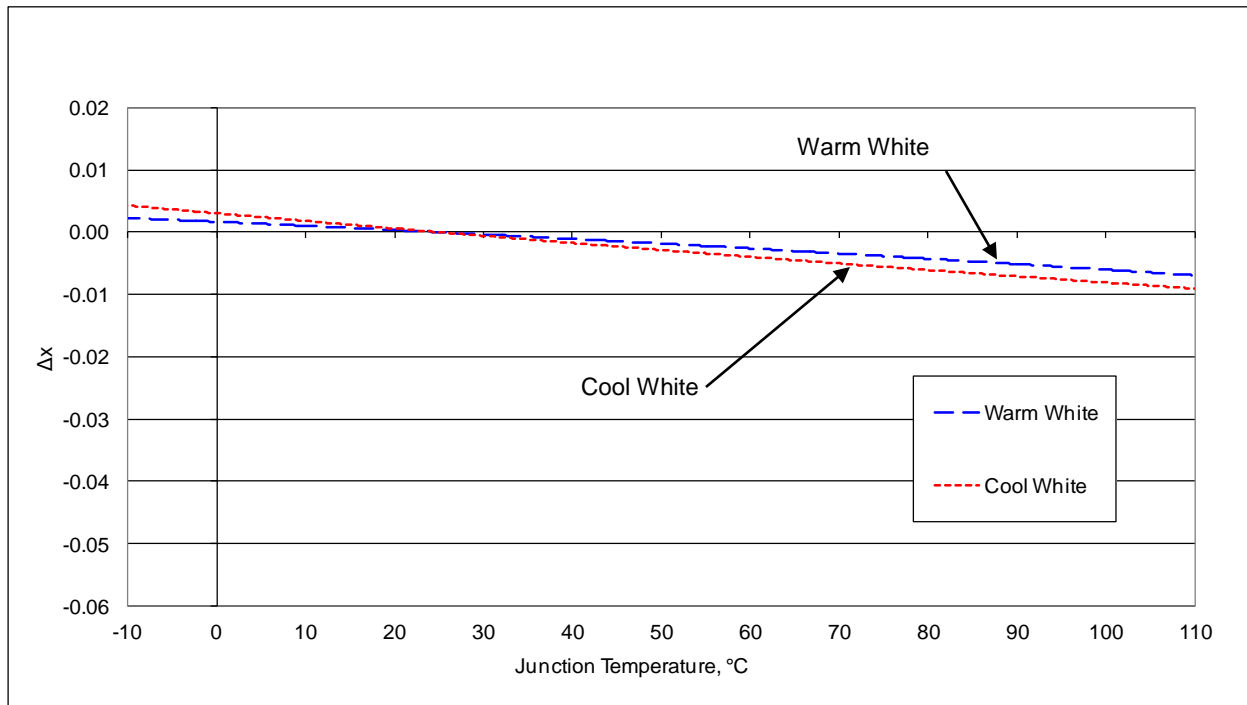

Figure 10: Typical ccy Shift vs. Junction Temperature

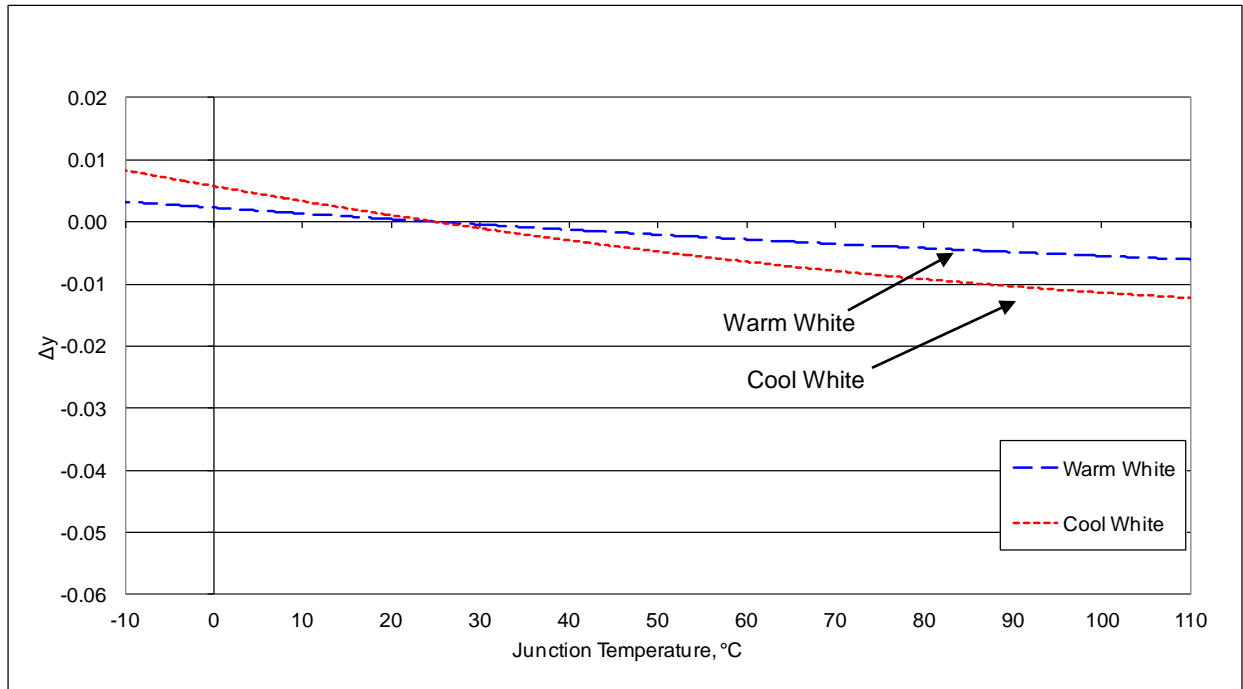



Figure 11: Forward Voltage versus Forward Current  
350mA 12V emitters (BXPX-xxxxxxx-A series products)

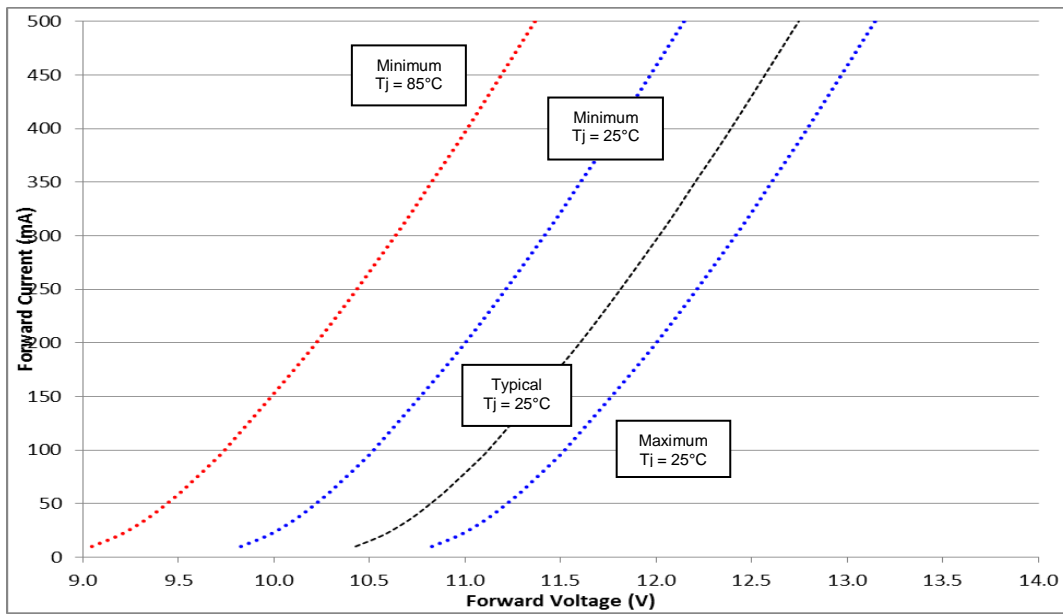
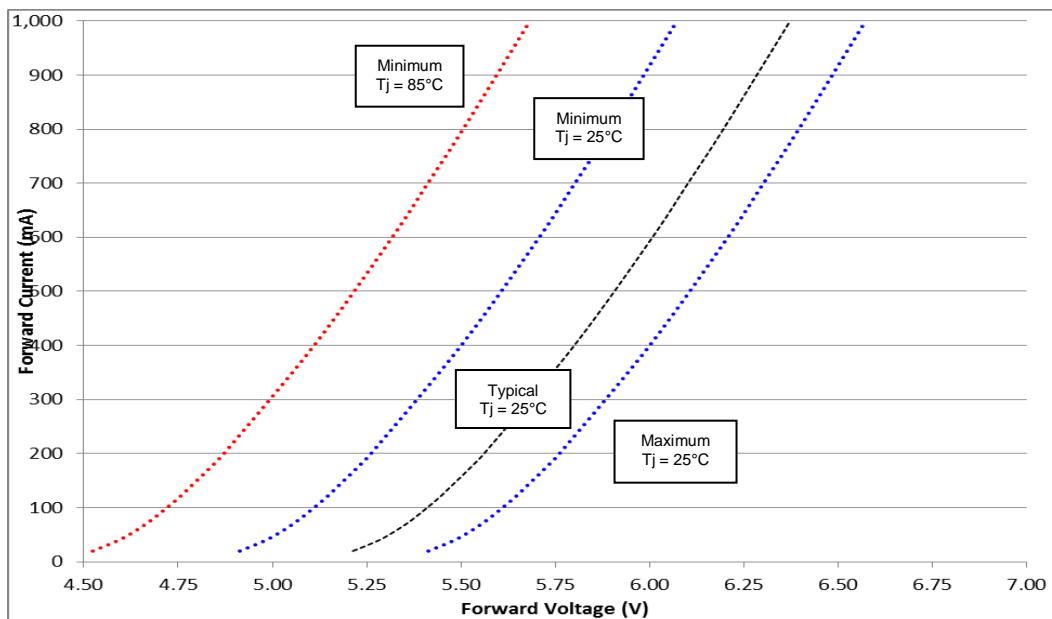

Figure 12: Forward Voltage versus Forward Current  
700mA 6V emitters (BXPX-xxxxxxx-B series products)



## Color Binning Information

Figure 13: Graph of 2700K Warm-White Test Bins in x, y Color Space

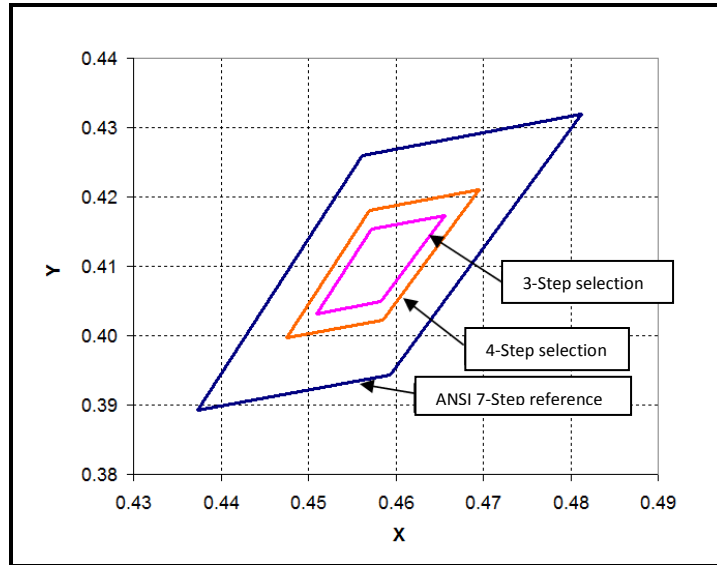

Table 8: 2700K Emitter Boundary Coordinates

	3 SDCM		4 SDCM	
	x	y	x	y
Center point	0.4578	0.4101	0.4578	0.4101
Top Right	0.4656	0.4174	0.4696	0.4210
Top Left	0.4573	0.4154	0.4570	0.4181
Bottom Left	0.4510	0.4032	0.4476	0.3997
Bottom Right	0.4583	0.4049	0.4586	0.4023

Applicable for part numbers BXPX-27x0400-x-0300 and BXPX-27x0400-x-0400

Notes for Table 8:

1. Bridgelux maintains a tester tolerance of  $\pm 0.003$  on x, y color measurements.

Color Binning Information (continued)

Figure 14: Graph of 3000K Warm-White Test Bins in x, y Color Space

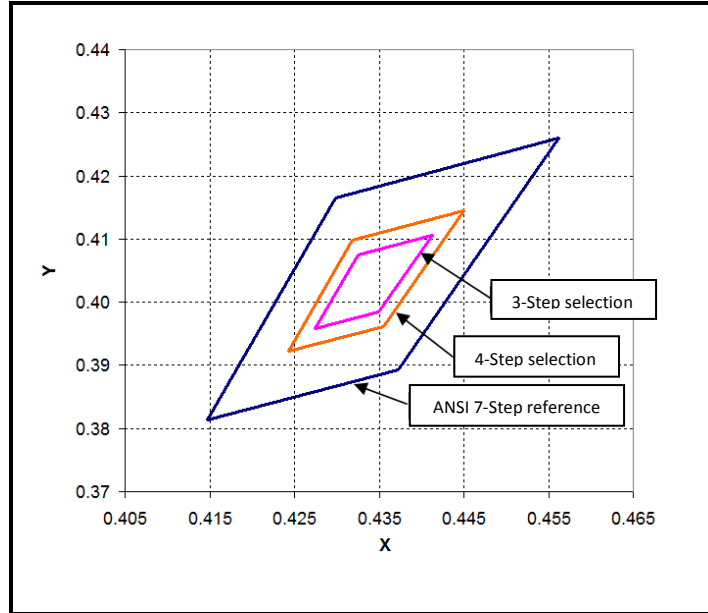

Table 9: 3000K Emitter Boundary Coordinates

	3 SDCM		4 SDCM	
	x	y	x	y
Center point	0.4338	0.4030	0.4338	0.4030
Top Right	0.4413	0.4107	0.4450	0.4145
Top Left	0.4325	0.4075	0.4319	0.4098
Bottom Left	0.4274	0.3958	0.4243	0.3922
Bottom Right	0.4350	0.3984	0.4356	0.3962

Applicable for part numbers BXPX-30x0400-x-0300 and BXPX-30x0400-x-0400

Notes for Table 9:

1. Bridgelux maintains a tester tolerance of  $\pm 0.003$  on x, y color measurements.

Color Binning Information (continued)

Figure 15: Graph of 5600K Cool-White Test Bins in x, y Color Space

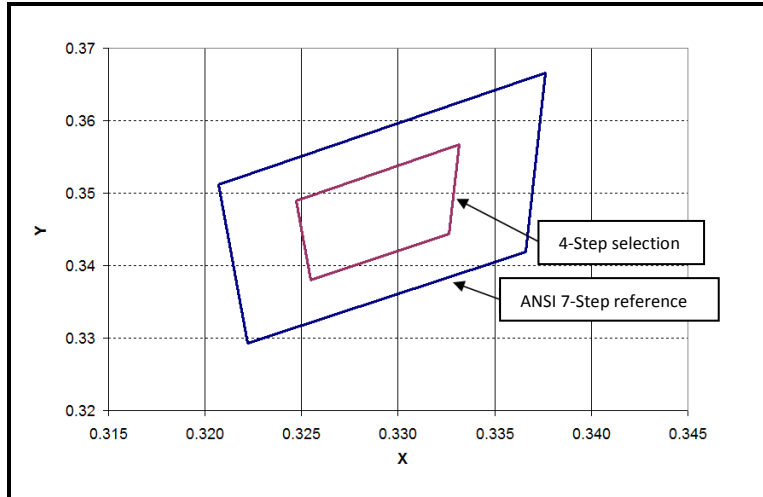

Table 10: 5600K Emitter Boundary Coordinates

	4 SDCM	
	x	y
Center point	0.3287	0.3417
Top Right	0.3332	0.3517
Top Left	0.3247	0.3440
Bottom Left	0.3255	0.3330
Bottom Right	0.3327	0.3393

Applicable for part numbers BXPX-56C0520-x-0400

Notes for Table 10:

1. Bridgelux maintains a tester tolerance of  $\pm 0.003$  on x, y color measurements.

## Packaging Drawings

Figure 16: Tape and Reel Dimensions

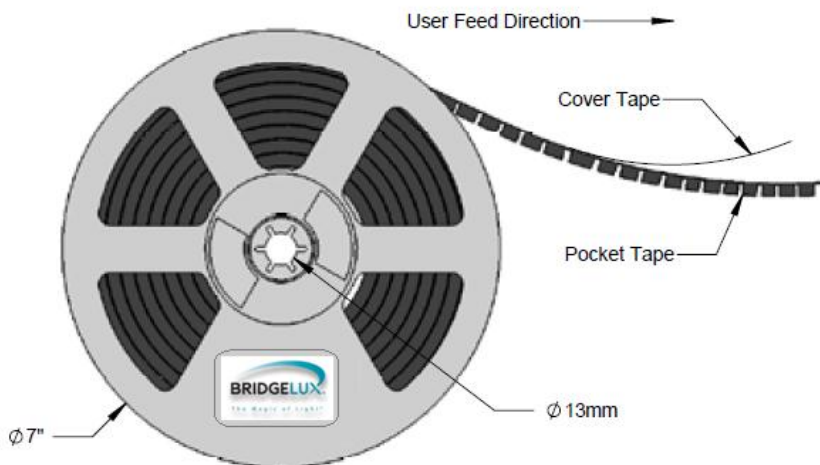
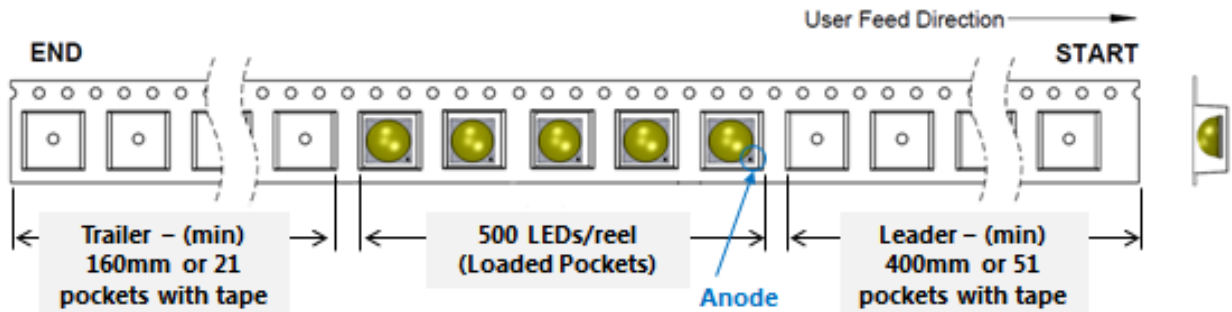

Notes for Figure 16:

1. Drawings are not to scale.
2. Drawing dimensions are in millimeters.
3. Unless otherwise specified, tolerances are  $\pm 0.20\text{mm}$ .
4. Conforms to EIA-481-D Standard for 12mm wide punched carrier tape.

---

## Design Resources

Bridgelux has developed a comprehensive set of application notes and design resources to assist in successfully designing with Bridgelux Micro SM4 products. Included below is a list of available resources which can be downloaded from the Bridgelux web site under the Design Resources section. These documents are updated regularly as new information becomes available, including complimentary infrastructure products such as commercially available secondary optics and electronic driver solutions.

### Application Notes

- AN20 : Effective Thermal Management of Bridgelux Micro SM4 Series LEDs
- AN21 : Handling and Assembly for Bridgelux Micro SM4 Series LEDs
- AN22 : Electrical Drive Considerations for Bridgelux Micro SM4 Series LEDs
- AN24 : Qualification Testing Summary for Bridgelux Micro SM4 Series LEDs
- AN26 : Optical Considerations for Bridgelux Micro SM4 Series LEDs

### 3D CAD Models

Three dimensional CAD models, depicting the product outline of the Bridgelux Micro SM4 LED, are available in both .igs and .stp formats. These CAD files can be downloaded directly from the Bridgelux web site at [www.bridgelux.com](http://www.bridgelux.com).

### Optical Source Models

Optical source models and ray trace files are available for the cool-white (5600K) and warm-white (2700K and 3000K) Micro SM4 emitters and can be downloaded directly from the Bridgelux website. The list below contains the formats currently available. Please contact your Bridgelux sales representative for assistance if you require a specific format not included in this list

- Photopia
- Light Tools
- Optis
- TracePro
- Zemax
- Radiant Source

---

## About Bridgelux

Bridgelux is a leading developer and manufacturer of technologies and solutions transforming the \$40 billion global lighting industry into a \$100 billion market opportunity. Based in Livermore, California, Bridgelux is a pioneer in solid-state lighting (SSL), expanding the market for light-emitting diode (LED) technologies by driving down the cost of LED lighting systems. Bridgelux's patented light source technology replaces traditional technologies (such as incandescent, halogen, fluorescent and high intensity discharge lighting) with integrated, solid-state lighting solutions that enable lamp and luminaire manufacturers to provide high performance and energy-efficient white light for the rapidly growing interior and exterior lighting markets, including street lights, commercial lighting and consumer applications. With more than 500 patent applications filed or granted worldwide, Bridgelux is the only vertically integrated LED manufacturer and developer of solid-state light sources that designs its solutions specifically for the lighting industry.

For more information about the company, please visit [www.bridgelux.com](http://www.bridgelux.com)

© 2012 Bridgelux, Inc. All rights reserved. Product specifications are subject to change without notice.

