

SEM203/P

PUSH BUTTON PT100 TX

Designed, manufactured and supported by:



Green Lane, Business Park, Green Lane
Tewkesbury Glos. G20 8DE. UK
Tel: +44 (0)1684 296818 Fax: +44 (0)1684 293746
Email: support@status.co.uk

Every effort has been taken to ensure the accuracy of this specification, however we do not accept responsibility for damage, injury, loss or expense resulting from errors and omissions, and we reserve the right of amendment without notice



1.0 DESCRIPTION

The SEM203/P head mounted temperature transmitter connects to any standard pt100 resistance sensor and converts the linearised temperature to a (4 to 20) mA signal. The transmitter is a two wire device, and is fully configurable by the user, over a wide temperature range, with the aid of a simple push button. This new SEM203/P design incorporates additional configuration menus, allowing the user to push button trim the transmitter output at both zero and span, ideal for trimming out sensor errors. The transmitters advanced circuitry guarantees high stability over the wide operating ambient temperature ranges experienced by head mounted devices.

One of the transmitters features is the program LED, which provides visual indication of sensor fault when in normal operation and is also used to guide the operator through the simple menus during configuration.

2.0 RECEIVING AND UNPACKING

Please inspect the packaging and instrument thoroughly for any signs of transit damage. If the instrument has been damaged, please notify your supplier immediately.

3.0 SPECIFICATION @ 20 °C

INPUT	
Sensor Type	PT100 100 R @ 0 °C 2 or 3 Wire
Sensor Range	(-200 to +850) °C (18 to 390) Ω
Sensor Connection	Screw terminal
Minimum span (see note 1)	25 °C
Linearisation	BS EN 60751 (IEC 751) standard / JISC1604
Accuracy (see note 2)	±0.1 °C ±0.05% of Reading
Thermal Drift	0.0025 % / °C
Excitation current	< 200 uA
Lead Resistance effect	0.002 °C / Ω
Maximum lead Resistance	20 Ω per leg

Note 1 Any span may be selected, full accuracy is only guaranteed for spans greater than the minimum recommended span.
Note 2 Basic measurement accuracy includes the effects of calibration, linearisation and repeatability

OUTPUT	
Type	Two wire (4 to 20) mA sink
Limits	Low <3.9 mA ; high 21.5 mA
Accuracy	±(mA out / 2000) or ±5 uA which ever greater
Loop Effect	± 0.2 uA / V measured @ 50 Hz 1 V (peak to peak)
Thermal Drift	± 1 uA / °C typical ; ±1.5 uA Max
Max Load	[(Vsupply - 10)/21] KΩ

GENERAL	
Update Time	0.5 Seconds
Response Time	1 Second to reach 90% of final value
Start up time	From power up typically 5 Seconds
Filter Factor	Adaptive
Ambient Temperature	(-40 to 85) °C
Config. Temp. Range	(10 to 40) °C
Connection	Screw Terminal
Approvals	BS EN 61326 ; 1998 – Electrical equipment for measurement and control ANNEX A ; ANNEX F

Factory Default (0 to 100) °C, upscale burnout, (0.0 °C user trim)

4.0 INSTALLATION AND WIRING

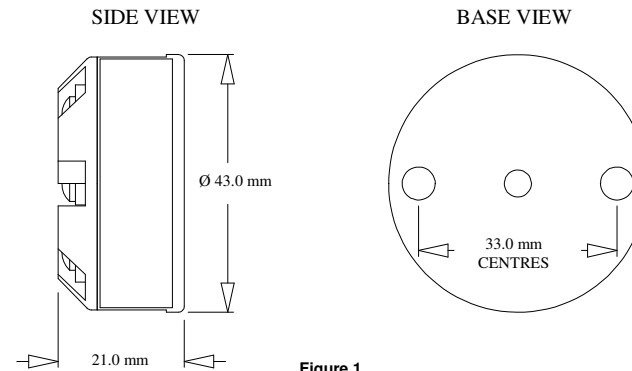

Mounting holes : two holes 5.5 mm diameter, 33 mm centres
Centre Hole sensor wire entry : 4 mm

4.1 Mechanical

The SEM203P transmitter has been specifically designed to fit inside a DIN standard probe head enclosure (such as the Status SCH-4 series), which provides adequate protection from moisture, dust, corrosive atmosphere etc. All cable entries must be sealed using the correct size gland. Likewise any probe assembly fitted must be sealed. Care must be taken when locating the transmitter to ensure the working ambient temperature range of (-40 to 85) °C is not exceeded. The SEM203P enclosure has a centre hole allowing the sensor wired to enter screw terminals from the transmitter centre, this is applicable when the sensor is mounted directly below the transmitter.

4.2 Electrical

Electrical connections to the transmitter are made to the screw terminal provided on the top face. The sensor wires must be equal length and type for the lead compensation to work correctly. The screw terminals allow for wires to enter either inner or outer direction. The transmitter is protected against reverse connection and over voltage. If no sensor (input) connection is made the transmitter will go into either up or down scale output current, depending on configuration. Figure 2 gives connection details, the output is shown connected to a 24 V supply. The load symbol represent any other device connected in the loop, such as Monitoring equipment, panel indicators and loop isolators. The load value can range from 0 ohms to the max loop load for given supply, refer to section 3 "Max load" for more information. The transmitter conforms with EC directive BS EN 61326 : 1998 when correctly installed in a termination head providing at least IP20 protection and with sensor wires less than 3 metres. Screened or twisted pair wires are recommended for output wires. Always ensure the (4 to 20) mA loop is grounded at one point, this would normally be at the monitoring equipment or loop power supply. In normal operation the program LED acts as over-range LED.

Figure 2

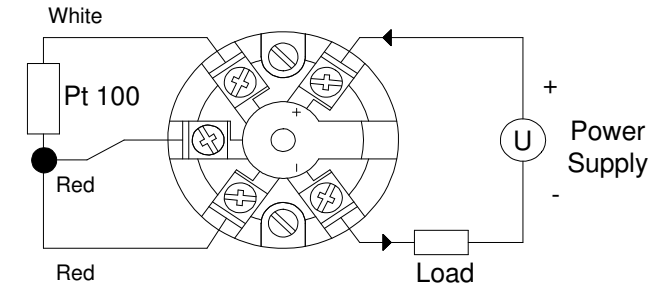

5.0 USER CONFIGURATION

IMPORTANT

READ COMPLETE SECTION BEFORE ATTEMPTING CONFIGURATION
PARTICULAR CARE SHOULD BE TAKEN REGARDING TIMEOUTS IN MENU 2 & 3

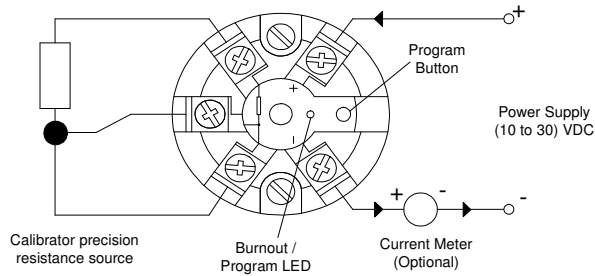

Figure 3 Configuration circuit

User Configuration

User configuration uses three menus, each menu sets a different parameter:-

Menu 1	Set range
Menu 2	Set direction of output on sensor burnout
Menu 3	User trim at 4 mA and 20 mA.

The configuration menus are navigated using the push button and program LED. The push button is located under the hole in the keyhole shaped wiring label. To press the button use a 3 mm screw driver (flat blade) inserted into the hole. The button has a slight click action.

Three types of button press are used:-

- Single button press = Advance
- Double press within 0.5 seconds = Escape or change direction
- Press and hold button > two seconds = Enter

When a menu is selected the Program LED will flash in bursts of one to three flashes, the number of flashes represents the menu number.

Navigating the menus

- To access menus, press and hold button > 2 second, then program LED will start to flash, one flash every burst. This indicates "menu 1" is selected.
- Use single button press to advance selection to "menu 2", the program LED will now show two flashes per burst. The Next single presses will advance the selected menu to menu 3 and the next single press will advance selected menu back to menu 1. Repeated single presses will cycle the selected menu back around menus 1 to 3, in the above sequence.
- Double press button to escape from menus, and return to normal. Normal operation can also be selected by turning transmitter power off and on. Note the transmitter will not time out and automatically escape from menus.

Using Menus

Menu 1 Range configuration (No Timeout)

Configuration will require the following tools and equipment :-

- DC Supply (12 to 30) V @ 30 mA
- Precision resistance decade box to simulate PT100 sensor. (Do not use electronic calibrator)
- Screw driver flat blade 3mm wide
- PT100 resistance tables
- Current meter (user trim)

To re-range the temperature scale follow the following instructions:-

- Refer to figure 3, connect resistance box to SEM203P input terminals using three wire connection. Connect output to a DC supply, observe polarity. Turn power on and allow 1 minute warm up period.
- Set calibrator to the equivalent resistance of the pt100 sensor, at required low range temperature. If the program LED is on at this stage the input is out of range, check resistance and connection.
- Press and hold button > 2 seconds to enter menus, menu 1 will then be selected, indicated by one flash every burst.
- Whilst menu 1 is selected, press and hold button > 2 seconds to enter menu 1, at which stage the program LED toggle on and off at a slow rate.
- Allow twenty seconds then single press button to store low range setting, the program LED will now flash at a fast rate.
- Set calibrator to the equivalent resistance of the pt100 sensor, at required high range temperature and allow twenty seconds.
- Press button to store high range setting, the program LED will flicker for one second before the transmitter returns to normal operation. The transmitter is now re-ranged.

Menu 2 Burnout Selection (Timeout is 3 Seconds)

- Refer to figure 3, Connect output to a DC supply, observe polarity. For this menu the input can be connected or open circuit. Turn power on.
- Press and hold button > 2 seconds to enter menus, menu 1 will then be selected, indicated by one flash every burst.
- Single press button to advance selection to menu 2, indicated by two flashes of the program LED every burst.
- Whilst menu 2 is selected, press and hold button > 2 seconds to enter menu 2, at which stage the program LED will either toggle on and off at a slow indicating low scale burnout or fast rate indicating upscale burnout.
- To change burnout direction single press button. The Program LED toggle rate will change to the other setting. Repeated single presses will toggle between up and down scale.
- To store setting allow 3 seconds with no button action, the program will then timeout, store new setting then return to normal operation.

Menu 3 User trim (Timeout is 20 Seconds)

This menu allows the user to trim the output current at 4 mA and 20 mA points, (similar function to trim potentiometers) and is very useful for trimming out sensor errors. The input of the transmitter must be connected to either a calibrator or a temperature sensor held at a known temperature. The (4 to 20) mA loop current will also need to be monitored with a current meter.

- Refer to figure 3, connect sensor or resistance box to SEM203P input terminals using three wire connection. Connect output to a DC supply, observe polarity, connect current meter in series with loop. Turn power on and allow 1 minute warm up period.
- Set calibrator to the equivalent resistance of the pt100 sensor, at required trim point. Alternatively ensure sensor temperature is at the required calibration point.
- The transmitter will automatically trim the 4 mA end if the output is within the active band of (3.8 to 6) mA, and trim the 20 mA end if the output is within the active band of (18 to 21.5) mA. No setting adjustment is performed if the output current is not within these two bands. Ensure your calibration points are within these bands.
- Press and hold button > 2 seconds to enter menus, menu 1 will then be selected, indicated by one flash every burst.
- Single press button to advance selection to menu 2, and single press again to select menu 3 indicated by three flashes of the program LED every burst.
- Whilst menu 3 is selected, press and hold button > 2 seconds to enter menu 3, at which stage the program LED toggle on and off at either a slow rate indicating downward trim direction or fast rate indicating upwards trim direction.
- To change trim direction double press button. The Program LED toggle rate will toggle to the opposite direction. Repeated double presses will toggle between up and down trim direction
- To trim output current, single press button to advance current 2 uA in set direction, or press and hold button to auto advance in set direction release button to stop advance. Note after approximately 20 seconds of continuous button press, the auto trim rate will speed up. Monitor the current change on the current meter.
- To store new setting allow 20 seconds with no button action, the program will then timeout, store new setting then return to normal operation.

Aid to User trim

- 1) Trim the 4 mA end first. The 4 mA trim is an offset adjustment and will affect both low and high ends, they will trim by the same amount (Fig 4)
- 2) Trimming the 20 mA end will not affect the 4 mA end. it will stretch or contract the 'span' between them. (Fig 5)

Reset to factory default settings

If required the SEM203P can be reset to factory default setting, this procedure also removes any user trim adjustment. Factory default settings are :

Range	(0 to 100) °C
Burnout	up-scale
User trim	All user adjustment cleared

To reset to factory setting, hold the button down whilst the SEM203P is powered up.

