

Sealed Polycarbonate and ABS Enclosures With Mounting Flange



Product Information:

- The lid and base incorporate a tongue and groove sealing system with a EPDM gasket.
- Wall mounting holes and lid fixing screws are outside the sealing area thus preventing the ingress of moisture and dust.
- Designed to IP65 of IEC 529 (Dust and Hoseproof).
- Bosses on internal base allow fixing of PCB's horizontally or connection of terminals with M3X4mm self-tapping screws.
- Internal guide slots for mounting PCB assemblies vertically.
- Available with clear or light grey lids.

Material

Polycarbonate (UL94-HB)

- Moulded in : Clear & Light Grey.
- Operating temperature: -40°C to 120°C.
- Clear lid is available.
- Mounting flange is designed on the bottom of the base, so the base can be mounted with pan head type of screws on the wall easily

High Impact ABS (UL94-HB)

- Moulded in : Dark Grey.
- Operating temperature: -20°C to 80°C
- Mounting flange is designed on the bottom of the base, so the base can be mounted with pan head type of screws on the wall easily.

Diagrams:

Part Number : MC001102 / MC001112 / MC001122

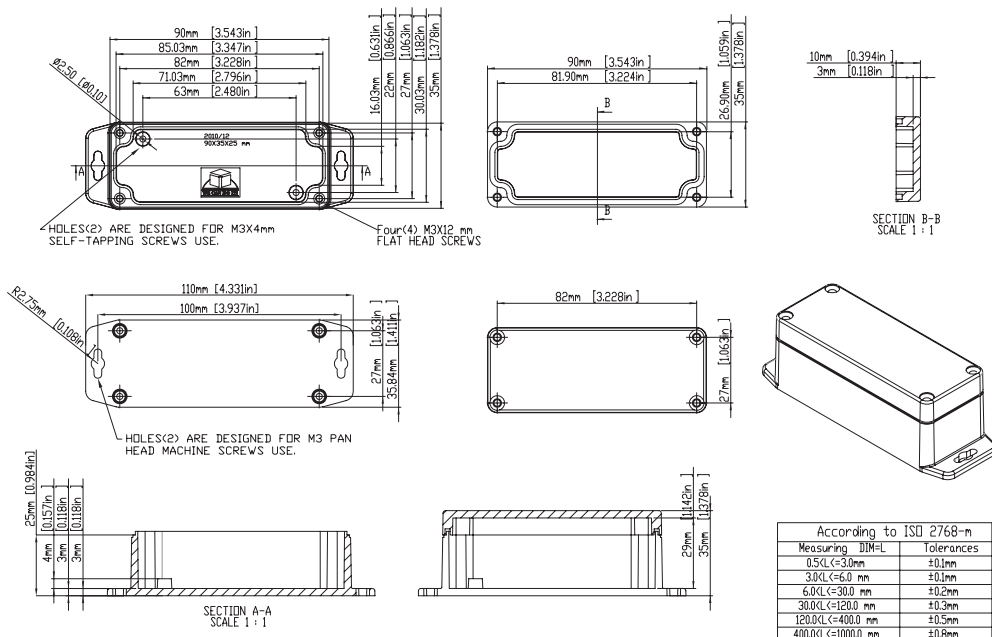

www.element14.com
www.farnell.com
www.newark.com



Sealed Polycarbonate and ABS Enclosures With Mounting Flange



Part Number : MC001093 / MC001103 / MC001113

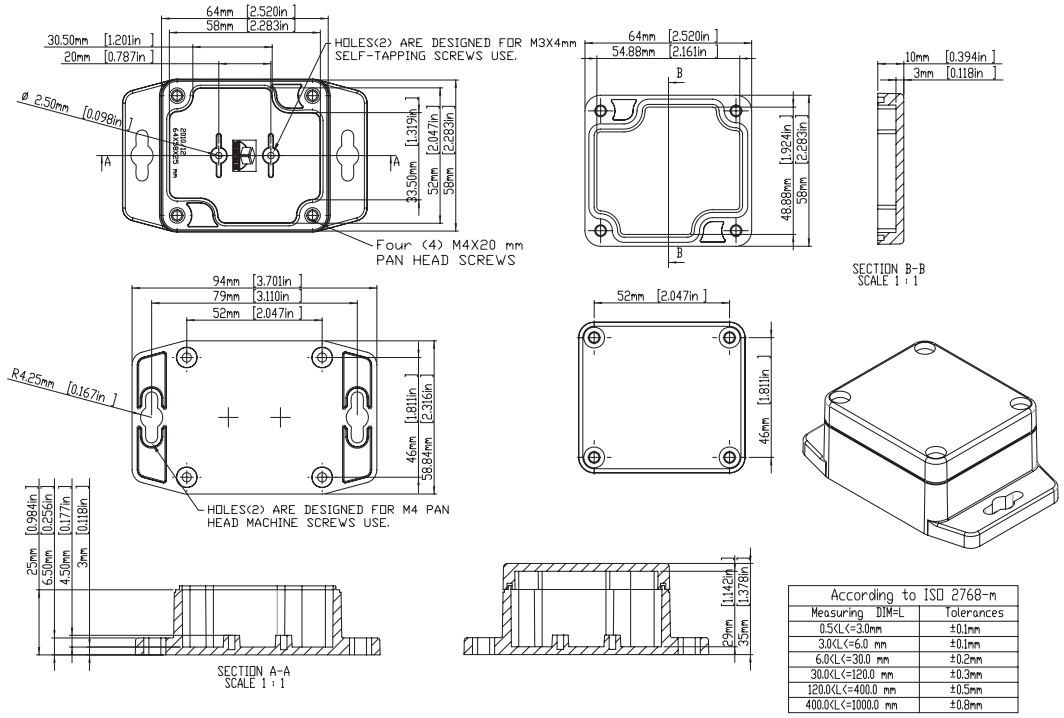

Part Number : MC001094 / MC001104 / MC001114

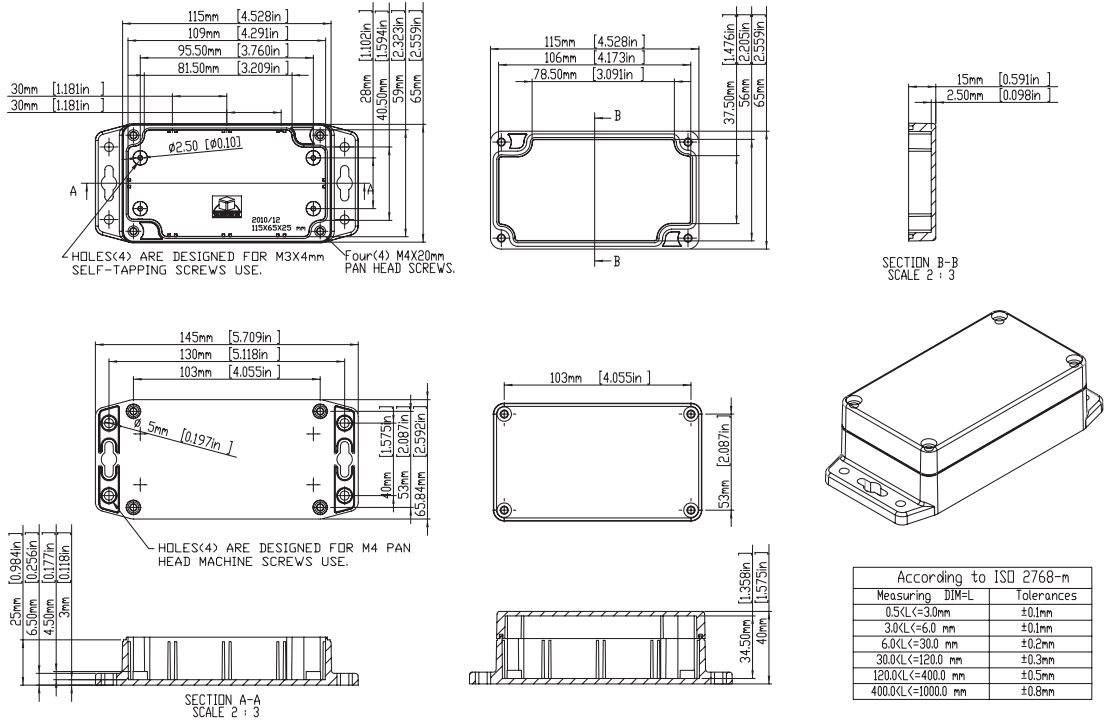

www.element14.com
www.farnell.com
www.newark.com



Sealed Polycarbonate and ABS Enclosures With Mounting Flange



Part Number : MC001095 / MC001105 / MC001115

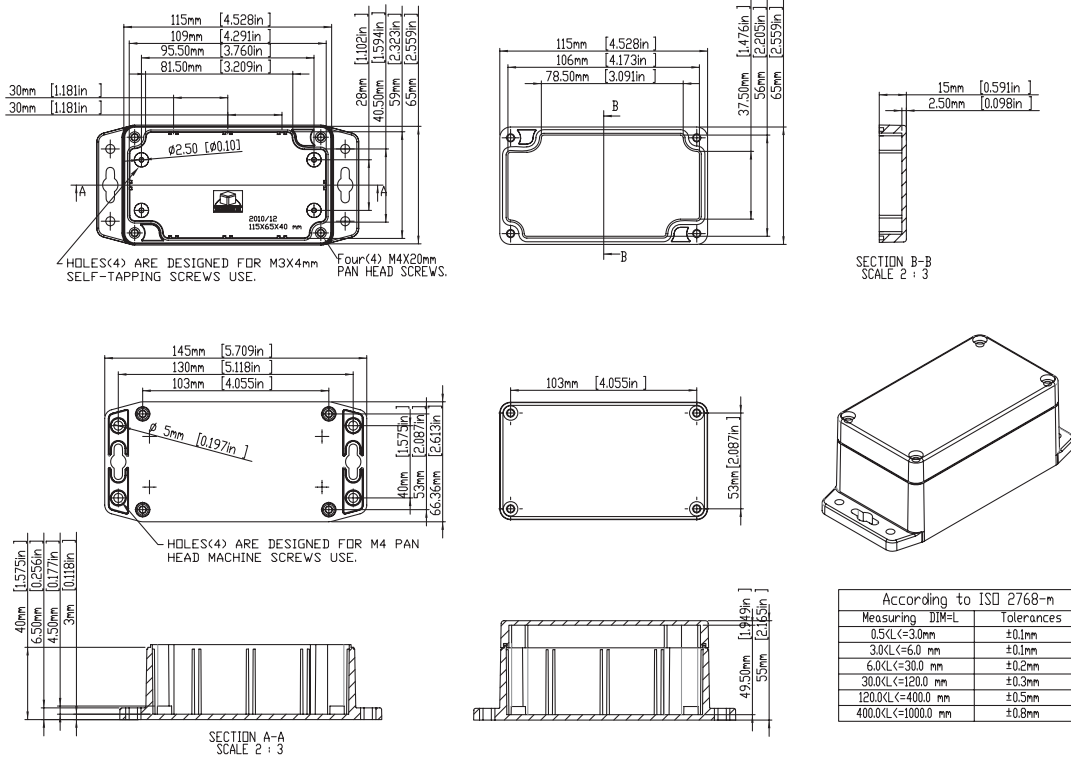

Part Number : MC001096 / MC001106 / MC001116

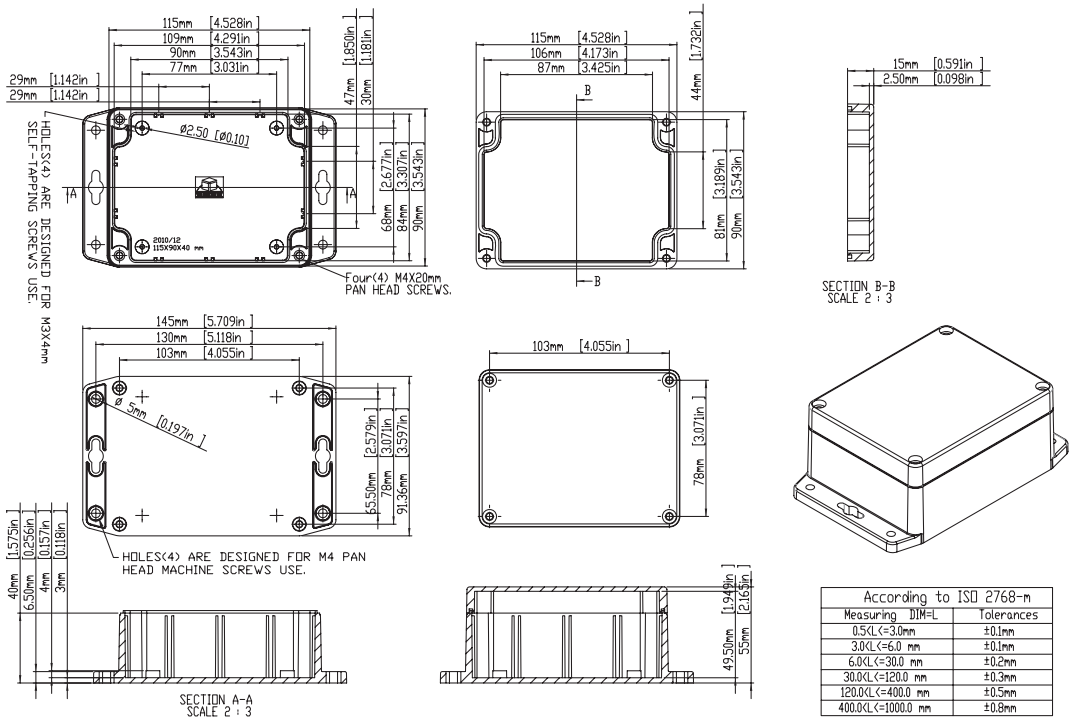

www.element14.com
www.farnell.com
www.newark.com



Sealed Polycarbonate and ABS Enclosures With Mounting Flange



Part Number : MC001098 / MC001108 / MC001118

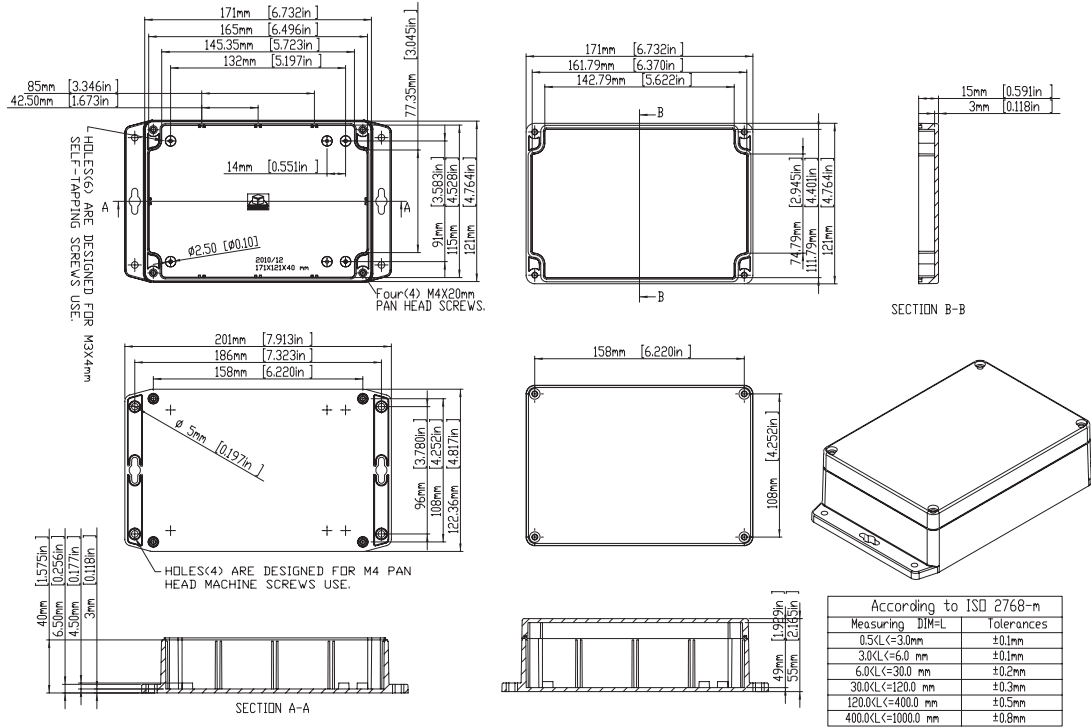

Part Number : MC001100 / MC001110 / MC001120

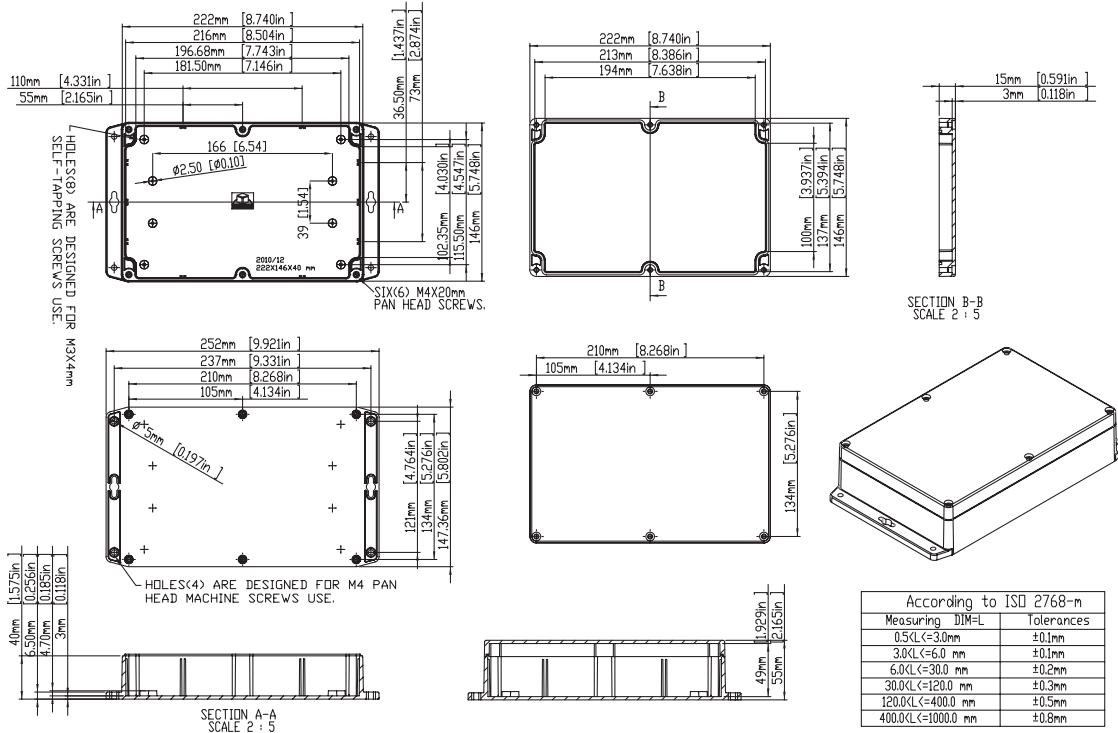

www.element14.com
www.farnell.com
www.newark.com



Sealed Polycarbonate and ABS Enclosures With Mounting Flange



Part Number : MC001097 / MC001107 / MC001117

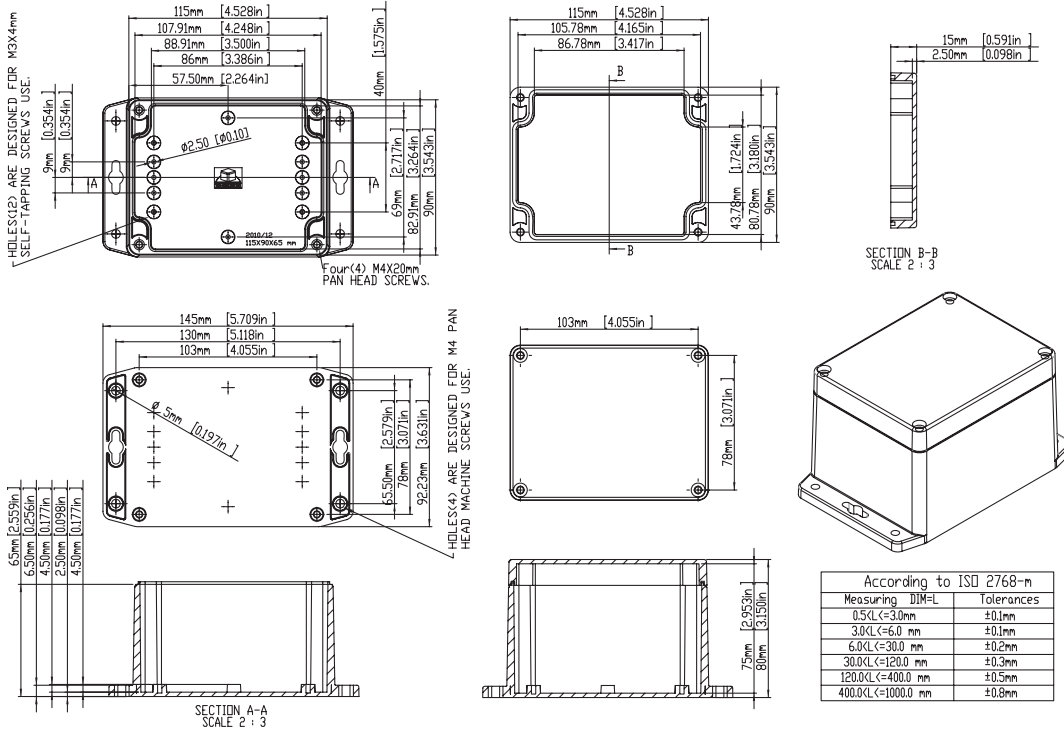

Part Number : MC001099 / MC001109 / MC001119

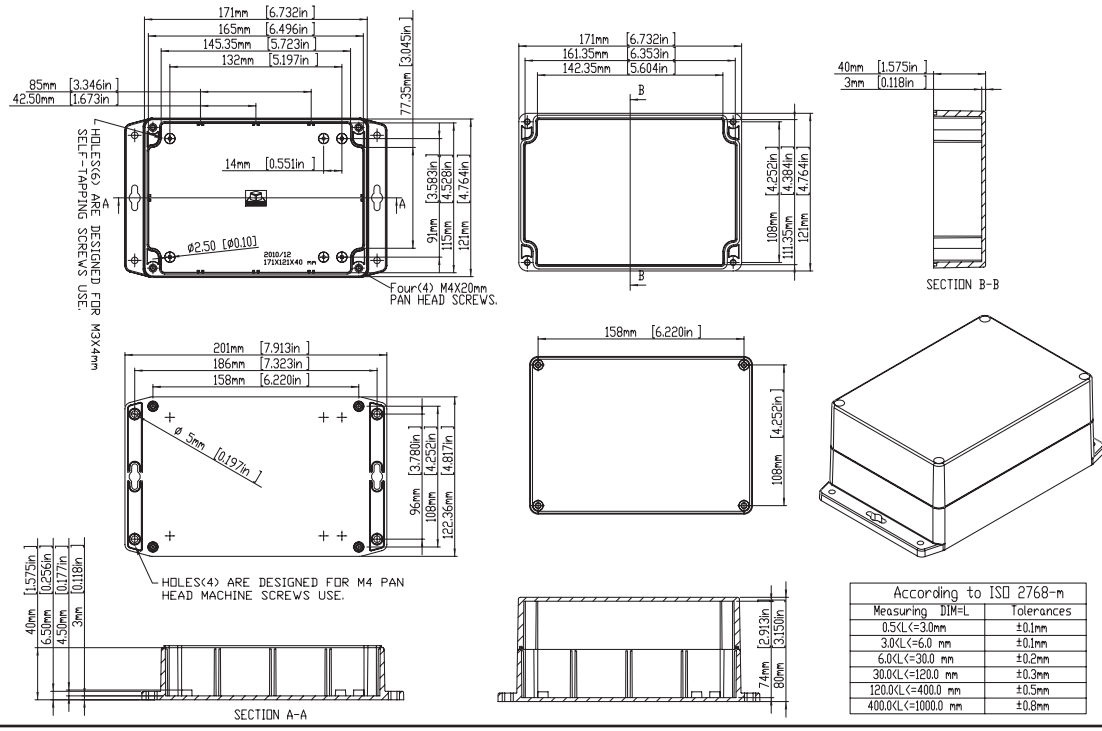

www.element14.com
www.farnell.com
www.newark.com



Sealed Polycarbonate and ABS Enclosures With Mounting Flange



Part Number : MC001101 / MC001111 / MC001121

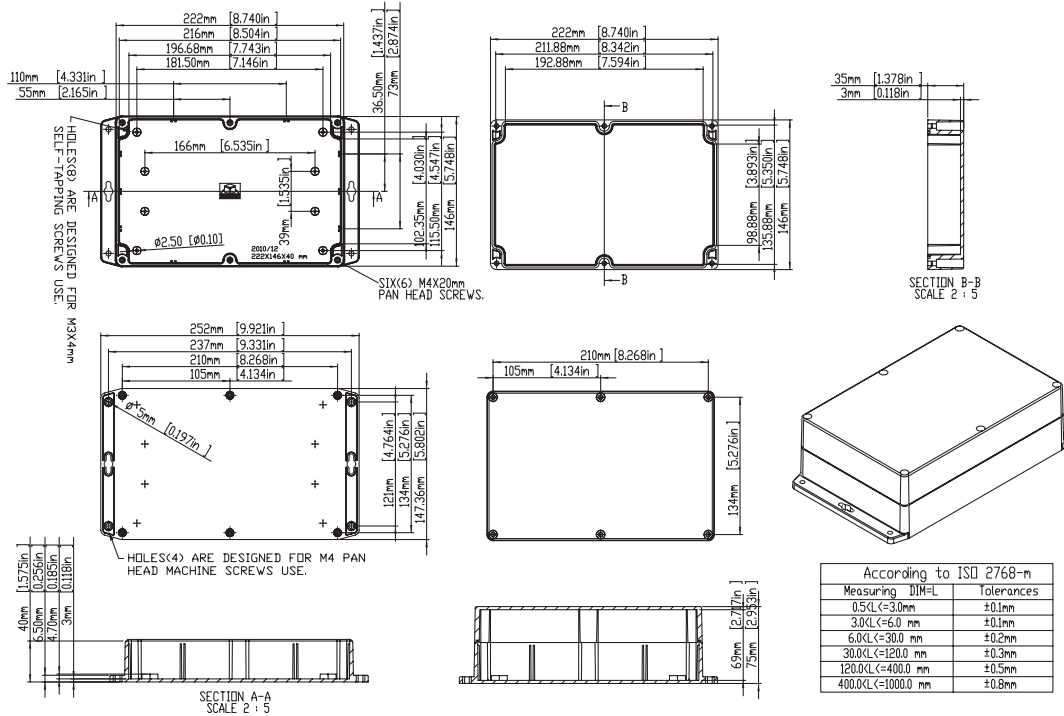

Part Number : MC001060 / MC001066 / MC001072

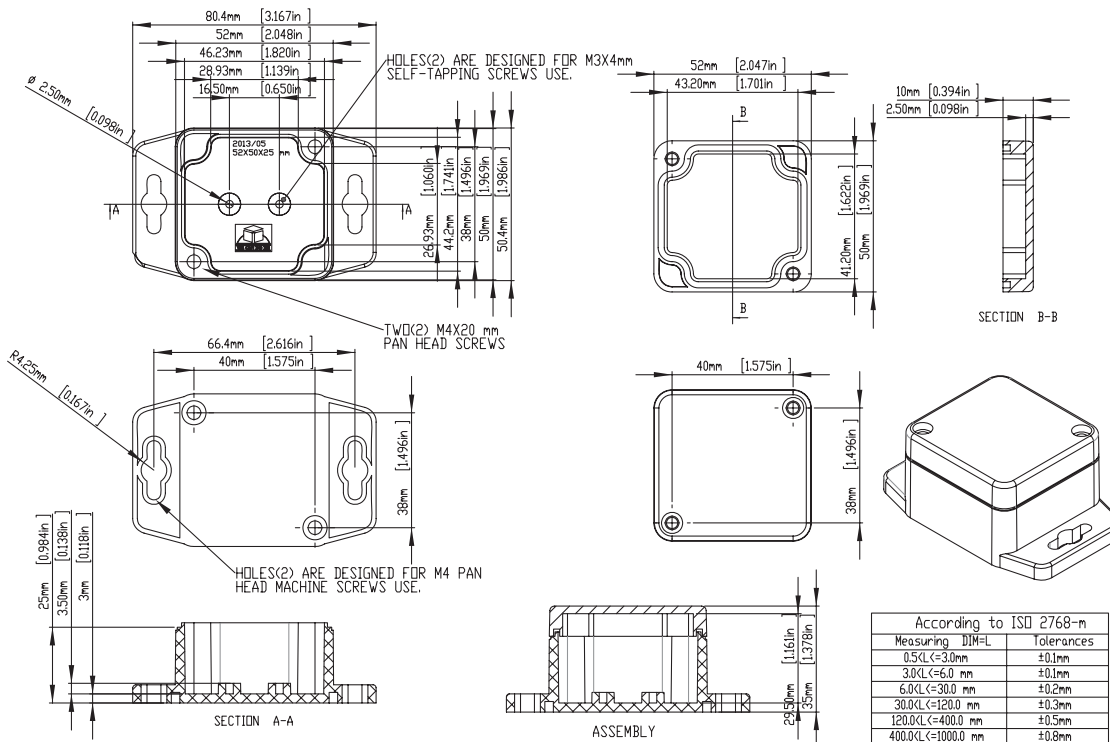

www.element14.com
www.farnell.com
www.newark.com



Sealed Polycarbonate and ABS Enclosures With Mounting Flange



Part Number : MC001061 / MC001067 / MC001073

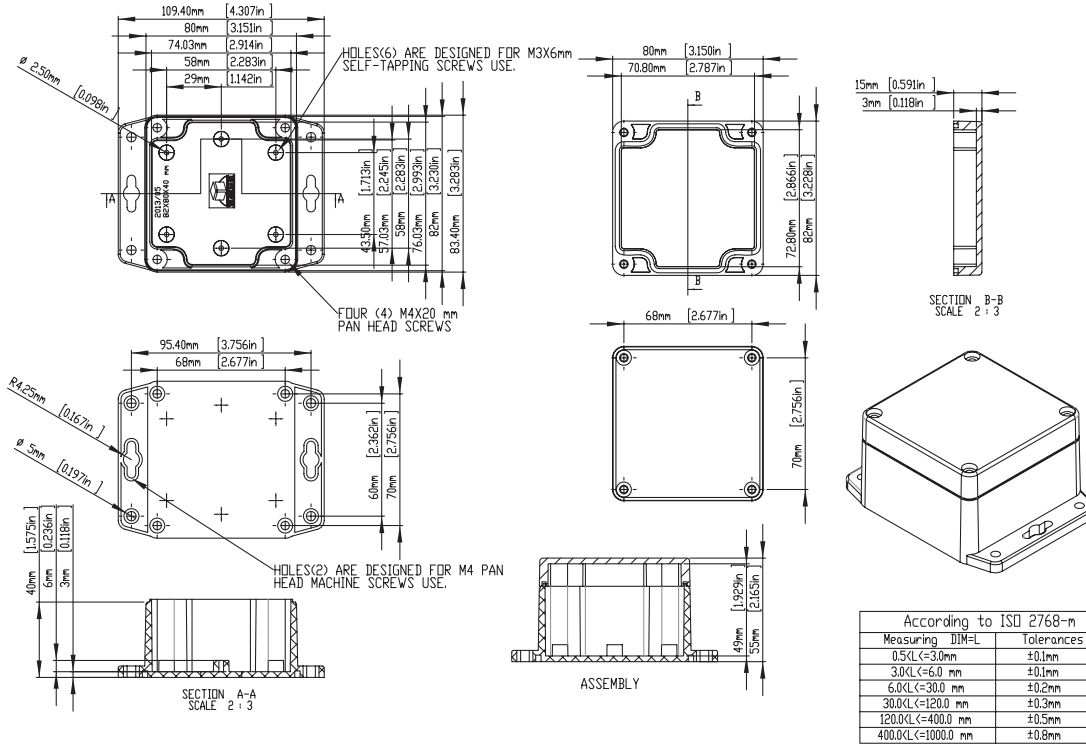

According to ISO 2768-m

Measuring DIM=L	Tolerances
0.5L <= 3.0mm	±0.1mm
3.0L <= 6.0 mm	±0.1mm
6.0L <= 30.0 mm	±0.2mm
30.0L <= 120.0 mm	±0.3mm
120.0L <= 400.0 mm	±0.5mm
400.0L <= 1000.0 mm	±0.8mm

Part Number : MC001062 / MC001068 / MC001074

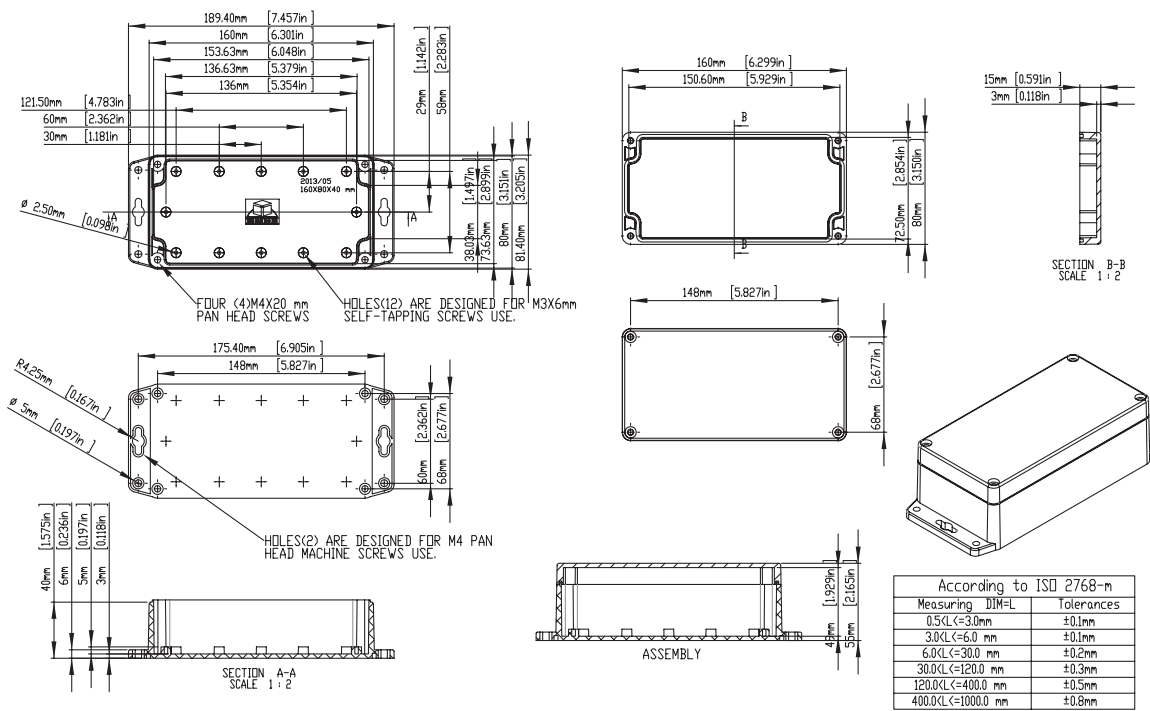

According to ISO 2768-m

Measuring DIM=L	Tolerances
0.5L <= 3.0mm	±0.1mm
3.0L <= 6.0 mm	±0.1mm
6.0L <= 30.0 mm	±0.2mm
30.0L <= 120.0 mm	±0.3mm
120.0L <= 400.0 mm	±0.5mm
400.0L <= 1000.0 mm	±0.8mm



Sealed Polycarbonate and ABS Enclosures With Mounting Flange



Part Number : MC001063 / MC001069 / MC001075

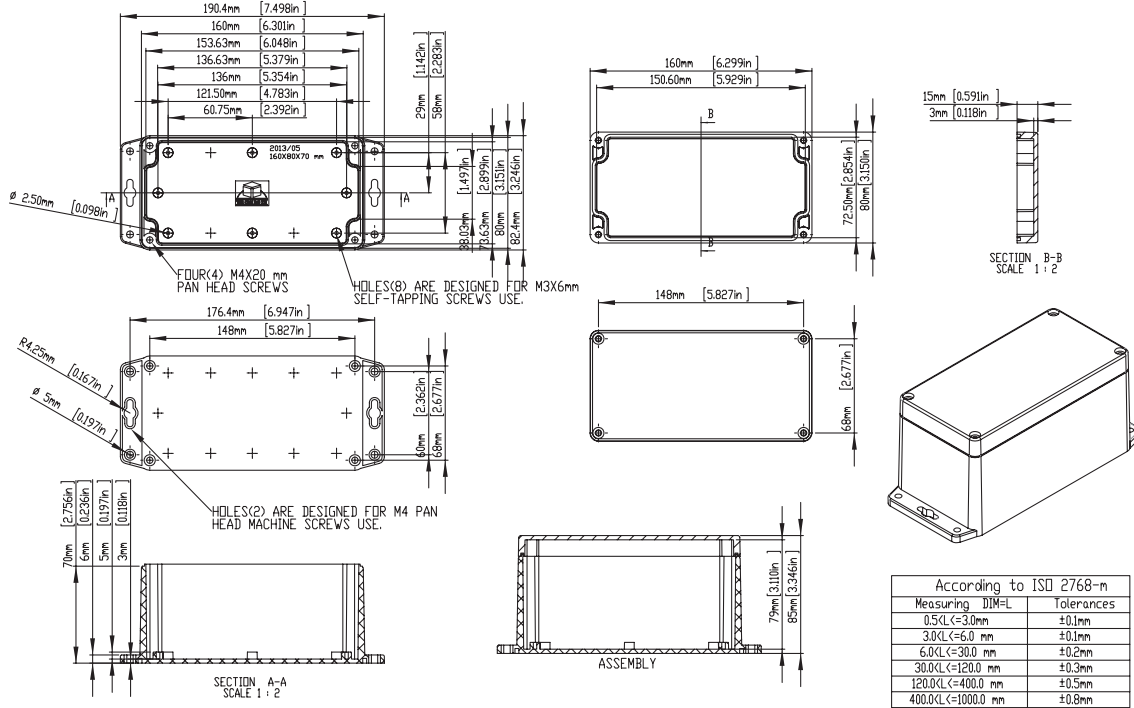

Part Number : MC001064 / MC001070 / MC001076

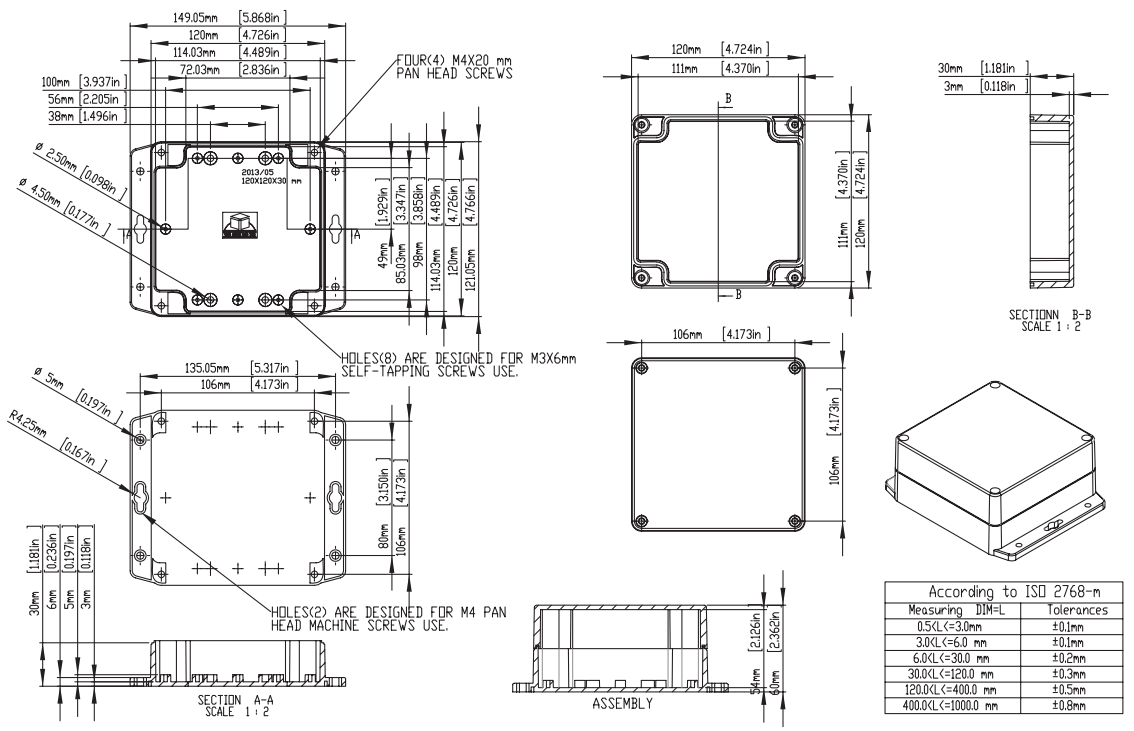

www.element14.com
www.farnell.com
www.newark.com



Sealed Polycarbonate and ABS Enclosures With Mounting Flange



Part Number : MC001065 / MC001071 / MC001077

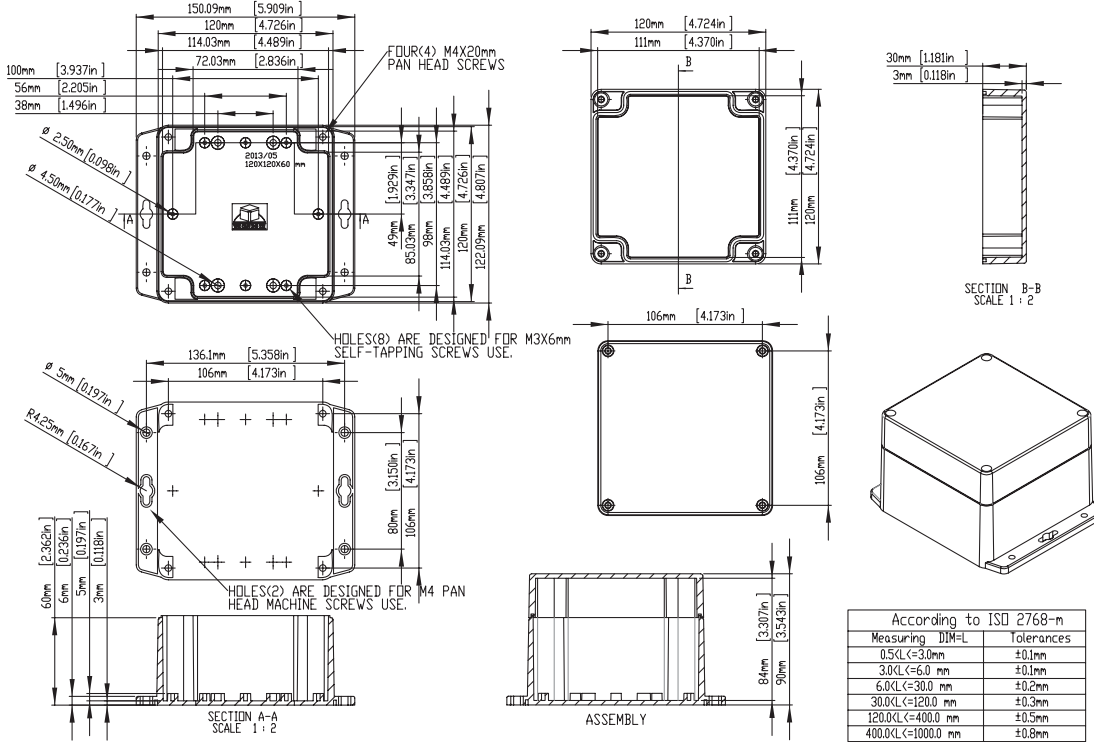

Part Number Table

Description	Material	Colour		External Dimension L x W x H (mm)	Part Number
		Lid	Base		
Sealed Polycarbonate and ABS Enclosures With Mounting Flange	Polycarbonate	Light Grey		90 x 35 x 35	MC001102
		Clear	Light Grey		MC001112
	ABS	Dark Grey			MC001122
	Polycarbonate	Light Grey		64 x 58 x 35	MC001093
		Clear	Light Grey		MC001103
	ABS	Dark Grey			MC001113
	Polycarbonate	Light Grey		115 x 65 x 40	MC001094
		Clear	Light Grey		MC001104
	ABS	Dark Grey			MC001114
	Polycarbonate	Light Grey		115 x 65 x 55	MC001095
		Clear	Light Grey		MC001105
	ABS	Dark Grey			MC001115
	Polycarbonate	Light Grey		115 x 90 x 55	MC001096
		Clear	Light Grey		MC001106
	ABS	Dark Grey			MC001116



Sealed Polycarbonate and ABS Enclosures With Mounting Flange



Description	Material	Colour		External Dimension L x W x H (mm)	Part Number
		Lid	Base		
Sealed Polycarbonate and ABS Enclosures With Mounting Flange	Polycarbonate	Light Grey		171 x 121 x 55	MC001098
		Clear	Light Grey		MC001108
	ABS	Dark Grey			MC001118
	Polycarbonate	Light Grey		222 x 146 x 55	MC001100
		Clear	Light Grey		MC001110
	ABS	Dark Grey			MC001120
	Polycarbonate	Light Grey		115 x 90 x 80	MC001097
		Clear	Light Grey		MC001107
	ABS	Dark Grey			MC001117
	Polycarbonate	Light Grey		171 x 121 x 80	MC001099
		Clear	Light Grey		MC001109
	ABS	Dark Grey			MC001119
	Polycarbonate	Light Grey		222 x 146 x 75	MC001101
		Clear	Light Grey		MC001111
	ABS	Dark Grey			MC001121
	Polycarbonate	Light Grey		52 x 50 x 35	MC001060
		Clear	Light Grey		MC001066
	ABS	Dark Grey			MC001072
	Polycarbonate	Light Grey		82 x 80 x 55	MC001061
		Clear	Light Grey		MC001067
	ABS	Dark Grey			MC001073
	Polycarbonate	Light Grey		160 x 80 x 55	MC001062
		Clear	Light Grey		MC001068
	ABS	Dark Grey			MC001074
	Polycarbonate	Light Grey		160 x 80 x 85	MC001063
		Clear	Light Grey		MC001069
	ABS	Dark Grey			MC001075
	Polycarbonate	Light Grey		120 x 120 x 60	MC001064
		Clear	Light Grey		MC001070
	ABS	Dark Grey			MC001076
Polycarbonate	Light Grey		120 x 120 x 90	MC001065	
	Clear	Light Grey		MC001071	
ABS	Dark Grey			MC001077	

Important Notice : This data sheet and its contents (the "Information") belong to the members of the Premier Farnell group of companies (the "Group") or are licensed to it. No licence is granted for the use of it other than for information purposes in connection with the products to which it relates. No licence of any intellectual property rights is granted. The Information is subject to change without notice and replaces all data sheets previously supplied. The Information supplied is believed to be accurate but the Group assumes no responsibility for its accuracy or completeness, any error in or omission from it or for any use made of it. Users of this data sheet should check for themselves the Information and the suitability of the products for their purpose and not make any assumptions based on information included or omitted. Liability for loss or damage resulting from any reliance on the Information or use of it (including liability resulting from negligence or where the Group was aware of the possibility of such loss or damage arising) is excluded. This will not operate to limit or restrict the Group's liability for death or personal injury resulting from its negligence. Multicomp is the registered trademark of the Group. © Premier Farnell plc 2012.