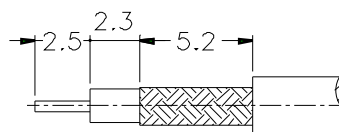
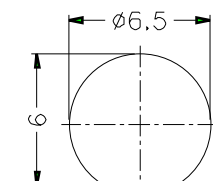
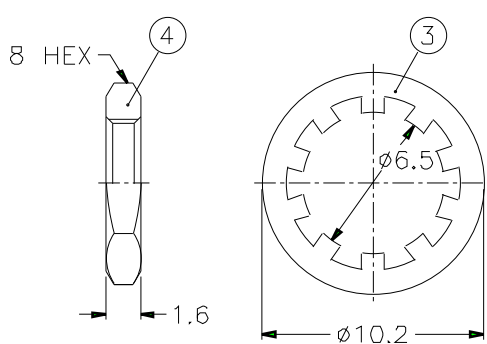
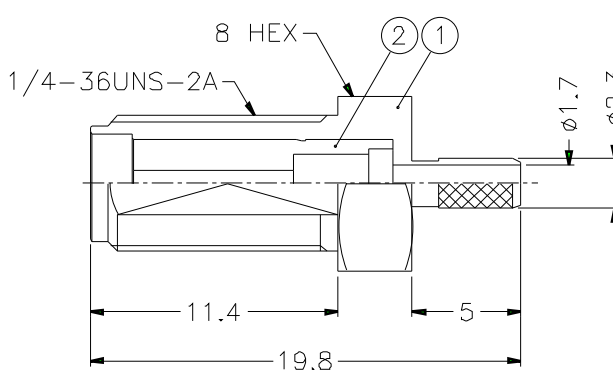
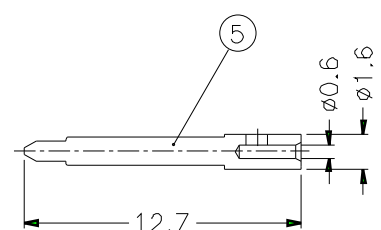
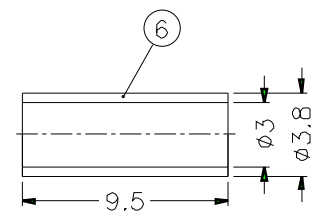
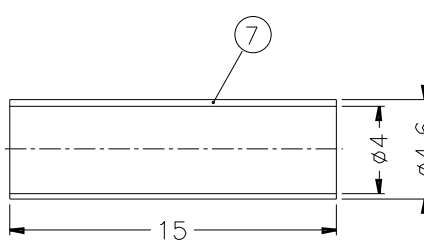

1		2		3		4		5		6		7		8			
REVISIONS																	
ISS	ZONE	DESCRIPTION\PER REQUEST\DATE															
 <p>RECOMMENDED CABLE STRIPPING DIM'S</p>  <p>RECOMMENDED MOUNTING HOLE</p>      <p>NOTES: FINISH (PLATING THICKNESS IN MICRO-INCHES)  1. BRASS PER QQ-B-626  2. BRASS PER QQ-B-613  3. NICKEL PL. 100 MIN. THICK OVER COPPER STRIKE  4. GOLD PL. 50 MIN. THICK OVER NICKEL PL. 100 MIN. THICK OVER COPPER STRIKE  5. TEFLON MIL-P-19468</p> <p>1. CRIMPED FERRULE  HEX CRIMP SIZE .128"  2. CRIMPED CONTACT PIN  SQ. CRIMP SIZE .052"  3. MAX. PANEL THICKNESS=3.2mm</p>																	
7	HEAT SHRINK TUBING		BLACK		HT-46/4X15	DIMENSIONS ARE IN MILLIMETERS UNLESS OTHERWISE SPECIFIED TOLERANCES 0.5-6 = ±0.2 6-30 = ±0.4 30-120 = ±0.6 120-315 = ±1 315-1000 = ±1.6 1000-2000 = ±2.4				PART NO. RSMA6411A2-NT50G-5-50		<h1 style="text-align: center;">Amphenol</h1> <p style="text-align: center;">TITLE SMA REVERSE POLARITY BULKHEAD CRIMP JACK (FOR RG-174/U,188A/U,316/U)</p> <p style="text-align: center;">DRAWING NO. KJ-RSMA6411A2-NT50G-316U-50</p> <p style="text-align: center;">ITEM NO.</p>					
6	FERRULE	COPPER	NOTE 3	1	FR-38/3X95C					APPROVED						DATE 10-11-01'	
5	CONTACT PIN	NOTE 1	NOTE 4	1	RSMA6111A2-3-16/06					CHECKED						DATE 10-11-01'	
4	HEX NUT	NOTE 1	NOTE 3	1	HN8-1/4-36X16					DRAWN						DATE 10-11-01'	
3	LOCK WASHER	NOTE 2	NOTE 3	1	LW-102/65X05					FILE NO.							
2	INSULATOR	NOTE 5	NATURAL	1	SMA7000-2T-50												
1	BODY	NOTE 1	NOTE 3	1	SMA6411A2-1-23/17-C												
NO.	DESCRIPTION	MATERIAL	FINISH	Q'TY	DRAWING NO.	SCALE	3/1	ISSUE	A	FILE NO.							

# Amphenol

TITLE SMA REVERSE POLARITY BULKHEAD CRIMP JACK (FOR RG-174/U,188A/U,316/U)

DRAWING NO. KJ-RSMA6411A2-NT50G-316U-50

ITEM NO.