



## Features

- Carbon element
- Metal housing
- 15-60 mm travel
- Single and dual gang
- Center detent option
- Dust cover option
- RoHS compliant\*

## Applications

- Audio/TV sets
- Car radio
- Amplifiers/mixers/drum machines/synthesizers
- PCs/monitors
- Appliances

# PTA Series - Low Profile Slide Potentiometer

### Electrical Characteristics

Taper .....Linear, audio  
 Standard Resistance Range  
 .....1 K ohms to 1 M ohms  
 Standard Resistance Tolerance ....±20 %  
 Residual Resistance  
 .....500 ohms or 1 % max.  
 Insulation Resistance  
 .....Min. 100 megohms at 250 V DC

### Environmental Characteristics

Operating Temperature  
 .....-10 °C to +50 °C  
 Power Rating, Linear  
 15 mm ....0.05 W (0.025 W Dual Gang)  
 20 mm .....0.1 W (0.05 W)  
 30 mm .....0.2 W (0.1 W)  
 45 mm .....0.25 W (0.125 W)  
 60 mm .....0.25 W (0.125 W)  
 Power Rating, Audio  
 15 mm ..0.025 W (0.015 W Dual Gang)  
 20 mm .....0.05 W (0.025 W)  
 30 mm .....0.1 W (0.05 W)  
 45 mm .....0.125 W (0.06 W)  
 60 mm .....0.125 W (0.06 W)  
 Maximum Operating Voltage, Linear  
 15 mm .....100 V DC  
 20-60 mm.....200 V DC  
 Maximum Operating Voltage, Audio  
 15 mm .....50 V DC  
 20-60 mm.....150 V DC  
 Withstand Voltage, Audio  
 .....1 Min. at 300 V AC  
 Sliding Noise .....100 mV maximum  
 Tracking Error.....3 dB at -40 to 0 dB

### Mechanical Characteristics

Operating Force .....30 to 250 g-cm  
 Stop Strength.....5 kg-cm min.  
 Sliding Life .....15,000 cycles  
 Soldering Condition  
 .....300 °C max. within 3 seconds  
 Travel .....15, 20, 30, 45, 60 mm

### Derating Curve

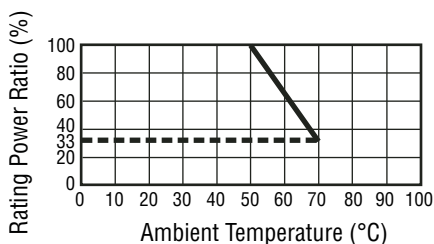

### Lever Style & Product Dimensions

#### Actuator Styles

##### DP METAL LEVER

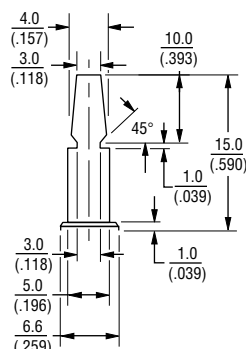

##### CP METAL LEVER

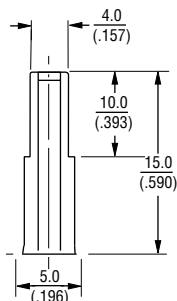

##### CI INSULATED LEVER

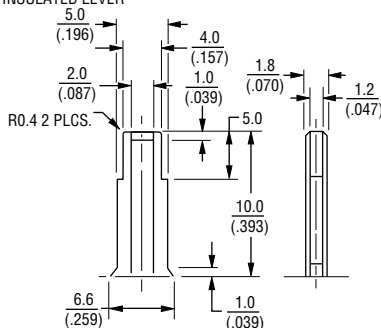

DIMENSIONS ARE:  $\frac{\text{MM}}{\text{(INCHES)}}$

### How To Order

**PTA 15 4 3 - 2 0 10 DP B 203**

Model \_\_\_\_\_

Stroke Length \_\_\_\_\_  
 • 15 = 15 mm  
 • 20 = 20 mm  
 • 30 = 30 mm  
 • 45 = 45 mm  
 • 60 = 60 mm

Dust Cover Option \_\_\_\_\_  
 • 4 = No Dust Cover  
 • 5 = Rubber Dust Cover

No. of Gangs \_\_\_\_\_  
 • 3 = Single Gang  
 • 4 = Dual Gang

Pin Style \_\_\_\_\_  
 • 2 = PC Pins Down Facing

Center Detent Option \_\_\_\_\_  
 • 0 = No Detent  
 • 2 = Center Detent

Standard Lever Length \_\_\_\_\_  
 (See Table)  
 • 10 = 10 mm (CI Lever)  
 • 15 = 15 mm (DP, CP and CI)

Lever Style \_\_\_\_\_  
 • DP = Metal Lever (Refer to Drawing)  
 • CP = Metal Lever (Refer to Drawing)  
 • CI = Insulated Lever (Refer to Drawing)

Resistance Taper \_\_\_\_\_  
 • A = Audio Taper  
 • B = Linear Taper

Resistance Code (See Table) \_\_\_\_\_

Other styles available \_\_\_\_\_

### Standard Resistance Table

Resistance (Ohms)	Resistance Code
1,000	102
2,000	202
5,000	502
10,000	103
20,000	203
50,000	503
100,000	104
200,000	204
500,000	504
1,000,000	105

\*RoHS Directive 2002/95/EC Jan 27 2003 including Annex. Specifications are subject to change without notice. Customers should verify actual device performance in their specific applications.

# PTA Series - Low Profile Slide Potentiometer

**BOURNS®**

## Product Dimensions

### PTAxx43

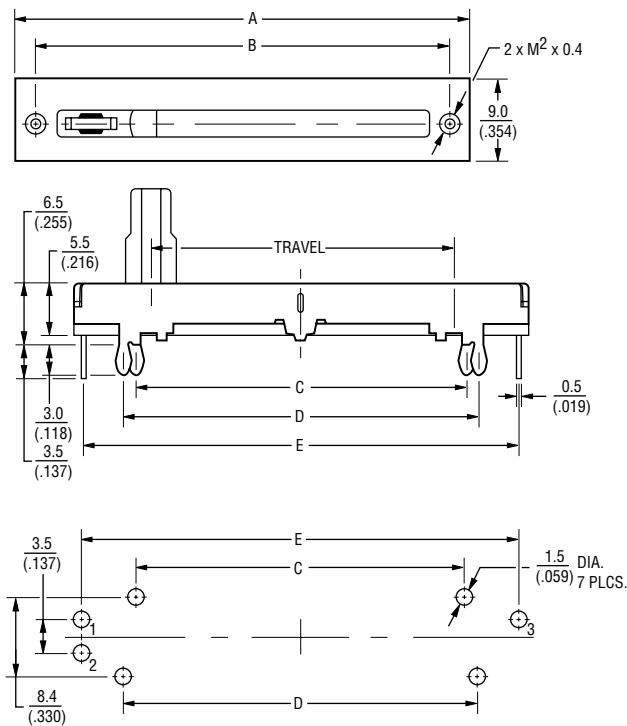

### PTAxx44

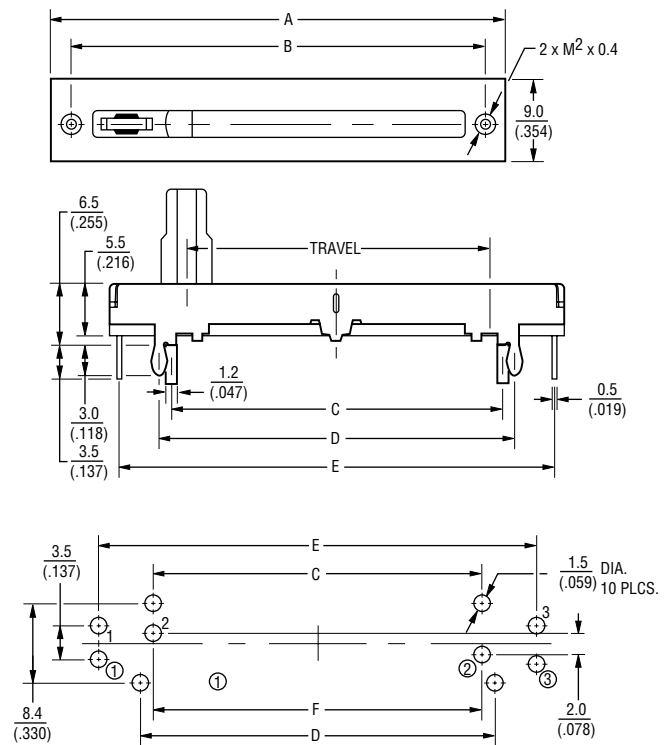

DIMENSIONS:  $\frac{\text{MM}}{(\text{IN.})}$

### Single Gang Dimensions

Model	A	B	C	D	E	Travel
PTA1543	30	26	17.8	20.2	28.5	15 mm
	(3.18)	(1.02)	(.700)	(.795)	(1.12)	(.59)
PTA2043	35	31	22.8	25.2	33.5	20 mm
	(1.37)	(1.22)	(.897)	(.992)	(1.31)	(.787)
PTA3043	45	41	32.8	35.2	43.5	30 mm
	(1.77)	(1.61)	(1.29)	(1.38)	(1.71)	(1.18)
PTA4543	60	56	47.8	50.2	58.5	45 mm
	(2.36)	(2.20)	(1.88)	(1.97)	(2.30)	(1.77)
PTA6043	75	71	62.8	65.2	73.5	60 mm
	(2.95)	(2.79)	(2.47)	(2.56)	(2.89)	(2.36)

### Dual Gang Dimensions

Model	A	B	C	D	E	F	Travel
PTA1544	30	26	17.8	20.2	28.5	18	15 mm
	(3.18)	(1.02)	(.700)	(.795)	(1.12)	(.708)	(.59)
PTA2044	35	31	22.8	25.2	33.5	23	20 mm
	(1.37)	(1.22)	(.897)	(.992)	(1.31)	(.905)	(.787)
PTA3044	45	41	32.8	35.2	43.5	33	30 mm
	(1.77)	(1.61)	(1.29)	(1.38)	(1.71)	(1.29)	(1.18)
PTA4544	60	56	47.8	50.2	58.5	48	45 mm
	(2.36)	(2.20)	(1.88)	(1.97)	(2.30)	(1.88)	(1.77)
PTA6044	75	71	62.8	65.2	73.5	63	60 mm
	(2.95)	(2.79)	(2.47)	(2.56)	(2.89)	(2.48)	(2.36)

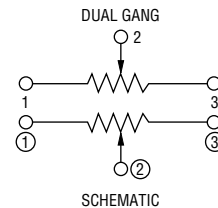
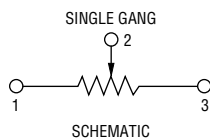

REV. 03/08

Specifications are subject to change without notice.  
Customers should verify actual device performance in their specific applications.