

Steady/Flashing LED Tower Lights

STG40/ STG50

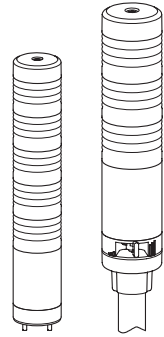

Thank you for purchasing Qlight's products. Please read this user manual carefully prior to installation and operation to ensure safe and correct use.

⚠️ Precautions for Safety

Failure to follow the instructions below may cause a loss of life or serious physical injury.

1. During wiring or maintenance, please completely turn off the power of the product. (Failure to follow this may lead to an electric shock.)
2. Do not install the product in locations that subjects it to excessive dust or water other than the conditions designated by the IP protection ratings indicated for each product. (Failure to follow these instructions may cause a fire to the product, electric shock, physical injury, malfunction or damage to the product.)
3. Do not alter or repair this product. If maintenance or repair service is required, please contact your local Qlight contact point. (Failure to follow these instructions may lead to fire, electric shock, or product damage.)
4. Please apply the correct voltage to the product. (Failure to follow these instructions may lead to fire, electric shock, or product damage.)
5. When the product is applied to a condition that may impact lives or property, please make sure to have a double safety device. (Failure to follow this may cause damage to property, fire, electric shock and loss of life.)

⚠️ Precautions for Correct Use

Failure to follow the proper instructions may cause damage to property, the product, and or malfunction of the product that would void the warranty.

1. Please remove any objects that can interrupt ventilation around the product.
2. Please turn off the power of the product immediately if it fails to operate properly.
3. Carefully wire the product according to each product's specification.
4. Please be careful in preventing chemicals such as thinner, benzene, etc. in contact with the surface of the product.
5. Do not apply excessive force/impact to the product.
6. Failure to follow any of the instructions above may cause malfunction or damage to the product, fire, and electric shock.

Ordering Specifications

STG40/ 50(M)L	3	110/220	RAG	LW18
[Model number]	[Layer count]	[Voltage]	[Color]	[Mounting option]
• STG40/ 50ML	• 1 Layer	• 12-DC12V	R-Red	• (Blank)
• STG40/ 50ML-BZ	• 2 Layers	• 24-DC24V	A-Amber	- Standard type
• STG40/ 50MLF	• 3 Layers	• 110/220 - AC110V~220V	G-Green	• Mounting type
• STG40/ 50MLF-BZ	• 4 Layers		B-Blue	-LB18 -LW18
• STG40/ 50L	• 5 Layers		W-White	-QZ18 -SZ18
• STG40/ 50L-BZ				-QL18 -SL18
• STG40/ 50LF				-QLA18
• STG40/ 50LF-BZ				



Please scan the QR code for more detailed product information.

www.qlight.com

Product Specifications

• STG40L

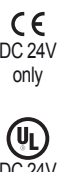
Model number	Layer count	Voltage	Current	Certificate	Weight	Color
STG40L Steady STG40L-BZ Steady /w built-in buzzer STG40LF Steady/ Flashing STG40LF-BZ Steady/ Flashing /w built-in buzzer	1	AC/DC12V AC/DC24V AC110V~220V	Max. 0.077A Max. 0.047A Max. 0.039A	 DC 24V only	0.29kg 0.29kg 0.31kg 0.31kg	R-Red
	2	AC/DC12V AC/DC24V AC110V~220V	Max. 0.154A Max. 0.094A Max. 0.049A		0.33kg 0.33kg 0.36kg 0.36kg	R-Red G-Green
	3	AC/DC12V AC/DC24V AC110V~220V	Max. 0.231A Max. 0.141A Max. 0.058A		0.38kg 0.38kg 0.40kg 0.40kg	R-Red A-Amber G-Green
	4	AC/DC12V AC/DC24V AC110V~220V	Max. 0.308A Max. 0.188A Max. 0.067A		0.45kg 0.45kg 0.47kg 0.47kg	R-Red A-Amber G-Green B-Blue
	5	AC/DC12V AC/DC24V AC110V~220V	Max. 0.385A Max. 0.235A Max. 0.076A		0.51kg 0.51kg 0.53kg 0.53kg	R-Red A-Amber G-Green B-Blue W-White

• STG40ML

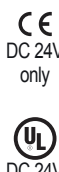
Model number	Layer count	Voltage	Current	Certificate	Weight	Color
STG40ML Steady STG40ML-BZ Steady /w built-in buzzer STG40MLF Steady/ Flashing STG40MLF-BZ Steady/ Flashing /w built-in buzzer	1	AC/DC12V AC/DC24V AC110V~220V	Max. 0.077A Max. 0.047A Max. 0.039A	 DC 24V only	0.12kg 0.12kg 0.14kg 0.14kg	R-Red
	2	AC/DC12V AC/DC24V AC110V~220V	Max. 0.154A Max. 0.094A Max. 0.049A		0.19kg 0.19kg 0.21kg 0.21kg	R-Red G-Green
	3	AC/DC12V AC/DC24V AC110V~220V	Max. 0.231A Max. 0.141A Max. 0.058A		0.25kg 0.25kg 0.27kg 0.27kg	R-Red A-Amber G-Green
	4	AC/DC12V AC/DC24V AC110V~220V	Max. 0.308A Max. 0.188A Max. 0.067A		0.31kg 0.31kg 0.33kg 0.33kg	R-Red A-Amber G-Green B-Blue
	5	AC/DC12V AC/DC24V AC110V~220V	Max. 0.385A Max. 0.235A Max. 0.076A		0.36kg 0.36kg 0.38kg 0.38kg	R-Red A-Amber G-Green B-Blue W-White

• STG50L

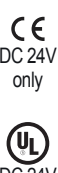
Model number	Layer count	Voltage	Current	Certificate	Weight	Color
STG50L Steady STG50L-BZ Steady /w built-in buzzer STG50LF Steady/ Flashing STG50LF-BZ Steady/ Flashing /w built-in buzzer	1	AC/DC12V AC/DC24V AC110V~220V	Max. 0.054A Max. 0.048A Max. 0.039A	 DC 24V only	0.36kg 0.36kg 0.38kg 0.38kg	R-Red
	2	AC/DC12V AC/DC24V AC110V~220V	Max. 0.108A Max. 0.096A Max. 0.049A		0.43kg 0.43kg 0.45kg 0.45kg	R-Red G-Green
	3	AC/DC12V AC/DC24V AC110V~220V	Max. 0.162A Max. 0.144A Max. 0.058A		0.53kg 0.53kg 0.55kg 0.55kg	R-Red A-Amber G-Green
	4	AC/DC12V AC/DC24V AC110V~220V	Max. 0.216A Max. 0.192A Max. 0.067A		0.59kg 0.59kg 0.61kg 0.61kg	R-Red A-Amber G-Green B-Blue
	5	AC/DC12V AC/DC24V AC110V~220V	Max. 0.270A Max. 0.240A Max. 0.076A		0.67kg 0.67kg 0.69kg 0.69kg	R-Red A-Amber G-Green B-Blue W-White

• STG50ML

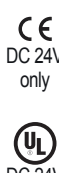
Model number	Layer count	Voltage	Current	Certificate	Weight	Color
STG50ML Steady STG50ML-BZ Steady /w built-in buzzer STG50MLF Steady/ Flashing STG50MLF-BZ Steady/ Flashing /w built-in buzzer	1	AC/DC12V AC/DC24V AC110V~220V	Max. 0.054A Max. 0.048A Max. 0.039A	 DC 24V only	0.20kg 0.20kg 0.22kg 0.22kg	R-Red
	2	AC/DC12V AC/DC24V AC110V~220V	Max. 0.108A Max. 0.096A Max. 0.049A		0.28kg 0.28kg 0.30kg 0.30kg	R-Red G-Green
	3	AC/DC12V AC/DC24V AC110V~220V	Max. 0.162A Max. 0.144A Max. 0.058A		0.36kg 0.36kg 0.38kg 0.38kg	R-Red A-Amber G-Green
	4	AC/DC12V AC/DC24V AC110V~220V	Max. 0.216A Max. 0.192A Max. 0.067A		0.45kg 0.45kg 0.47kg 0.47kg	R-Red A-Amber G-Green B-Blue
	5	AC/DC12V AC/DC24V AC110V~220V	Max. 0.270A Max. 0.240A Max. 0.076A		0.53kg 0.53kg 0.55kg 0.55kg	R-Red A-Amber G-Green B-Blue W-White

• STG40

Signal/ Audible line current(Per each layer)			
Current	AC/DC12V	AC/DC24V	AC110V~220V
Signal line current	0.077A	0.047A	0.039A
Audible line current	0.043A	0.064A	0.041A

• STG50

Signal/ Audible line current(Per each layer)			
Current	AC/DC12V	AC/DC24V	AC110V~220V
Signal line current	0.054A	0.048A	0.039A
Audible line current	0.042A	0.063A	0.045A

Dimensions

(Units : mm)

•STG40(M)L

STG40ML : DC
STG40MLF : DC
STG40ML-BZ : DC

STG40ML : AC
STG40MLF-BZ : DC

STG40MLF : AC
STG40ML-BZ : AC
STG40MLF-BZ : AC

STG40L : DC
STG40LF : DC
STG40L-BZ : DC

STG40L : AC
STG40LF-BZ : DC

STG40LF : AC
STG40L-BZ : AC
STG40LF-BZ : AC

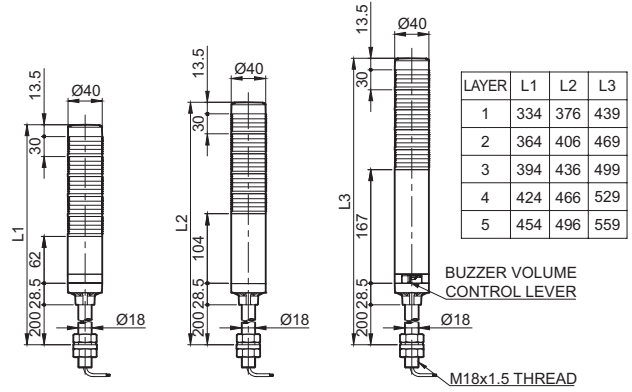
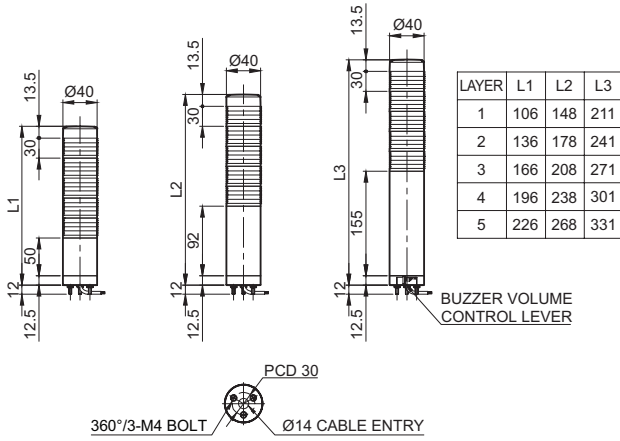

•STG50(M)L

STG50ML : DC
STG50MLF : DC
STG50ML-BZ : DC

STG50MLF-BZ : DC

STG50ML : AC
STG50MLF : AC
STG50ML-BZ : AC
STG50MLF-BZ : AC

STG50L : DC
STG50LF : DC
STG50L-BZ : DC

STG50LF-BZ : DC

STG50L : AC
STG50LF : AC
STG50L-BZ : AC
STG50LF-BZ : AC

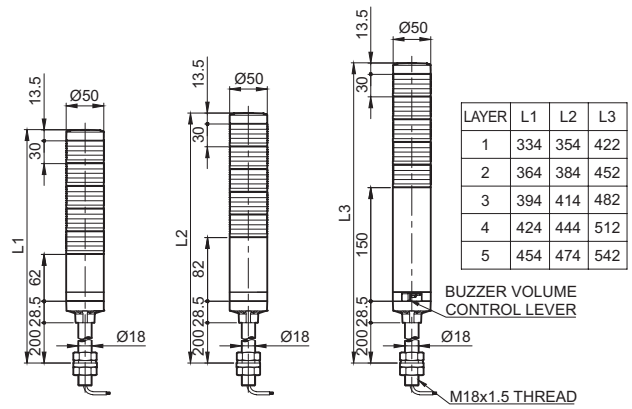
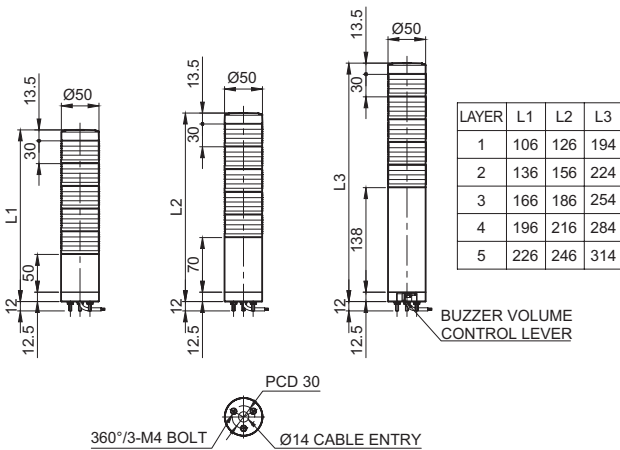

Wiring Instructions

■ Wiring using external contact

- In case of wiring with external contacts, refer to the wiring diagrams below according to your product's type and voltage setting.

	Wiring diagrams		Wiring diagrams
DC Steady	<p>External contact</p> <p>Red Layer 1 Amber Layer 2 Green Layer 3 Blue Layer 4 White Layer 5 Brown Buzzer Black Fuse Power</p> <p>STG40ML STG40L STG50ML STG50L</p> <ul style="list-style-type: none"> • STG□□(M)L - Refer to this diagram for buzzer type product • STG□□L <ul style="list-style-type: none"> └ Lens diameter 40(40mm) : STG40(M)L 50(50mm) : STG50(M)L 	AC Steady	<p>External contact</p> <p>Red Layer 1 Amber Layer 2 Green Layer 3 Blue Layer 4 White Layer 5 Brown Buzzer Black Common White Common Black Fuse Power</p> <p>STG40ML STG40L STG50ML STG50L</p> <ul style="list-style-type: none"> • STG□□(M)L - Refer to this diagram for buzzer type product • STG□□L <ul style="list-style-type: none"> └ Lens diameter 40(40mm) : STG40(M)L 50(50mm) : STG50(M)L
DC Steady/Flashing	<p>External contact</p> <p>Red Layer 1 Amber Layer 2 Green Layer 3 Blue Layer 4 White Layer 5 Brown Buzzer Black Common White Common Black Fuse Power</p> <p>STG40MLF STG40LF STG50MLF STG50LF</p> <ul style="list-style-type: none"> • STG□□(M)LF - Refer to this diagram for buzzer type product • STG□□LF <ul style="list-style-type: none"> └ Lens diameter 40(40mm) : STG40(M)LF 50(50mm) : STG50(M)LF 	AC Steady/Flashing	<p>External contact</p> <p>Red Layer 1 Amber Layer 2 Green Layer 3 Blue Layer 4 White Layer 5 Brown Buzzer Black Common Gray Common White Fuse Black Power</p> <p>STG40MLF STG40LF STG50MLF STG50LF</p> <ul style="list-style-type: none"> • STG□□(M)LF - Refer to this diagram for buzzer type product • STG□□LF <ul style="list-style-type: none"> └ Lens diameter 40(40mm) : STG40(M)LF 50(50mm) : STG50(M)LF

- DC steady type cable specification : External power/ signal line - UL1007 AWG22(0.3sq) 400mm
- AC steady, AC/DC steady/flashing type cable specification : External power line - UL1015 AWG18(0.75sq) × 2C 400mm,
External signal line - UL1007 AWG22(0.3sq) 400mm

■ Wiring using transistor

- When using a transistor, please choose between the NPN or PNP type transistor which best matches the voltage and product type, then connect them correctly according to the wiring diagrams below.

		Wiring diagrams	
DC Steady		<p>NPN - Transistor External Transistor-NPN</p> <p>PNP - Transistor External Transistor-PNP</p> <p>STG40ML STG40L STG50ML STG50L</p> <ul style="list-style-type: none"> • STG□□(M)LF - Refer to this diagram for buzzer type product • STG□□L <ul style="list-style-type: none"> └ Lens diameter 40(40mm) : STG40(M)LF 50(50mm) : STG50(M)LF 	
DC Steady/Flashing		<p>PNP - Transistor External Transistor-PNP</p> <p>STG40MLF STG40LF STG50MLF STG50LF</p> <ul style="list-style-type: none"> • STG□□(M)LF - Refer to this diagram for buzzer type product • STG□□LF <ul style="list-style-type: none"> └ Lens diameter 40(40mm) : STG40(M)LF 50(50mm) : STG50(M)LF 	<p>AC Steady/Flashing</p> <p>PNP - Transistor External Transistor-PNP</p> <p>STG40MLF STG40LF STG50MLF STG50LF</p> <ul style="list-style-type: none"> • STG□□(M)LF - Refer to this diagram for buzzer type product • STG□□LF <ul style="list-style-type: none"> └ Lens diameter 40(40mm) : STG40(M)LF 50(50mm) : STG50(M)LF

- DC steady type cable specification : External power/ signal line - UL1007 AWG22(0.3sq) 400mm
- AC steady, AC/DC steady/flashing type cable specification : External power line - UL1015 AWG18(0.75sq) × 2C 400mm, External signal line - UL1007 AWG22(0.3sq) 400mm

Parts Definition

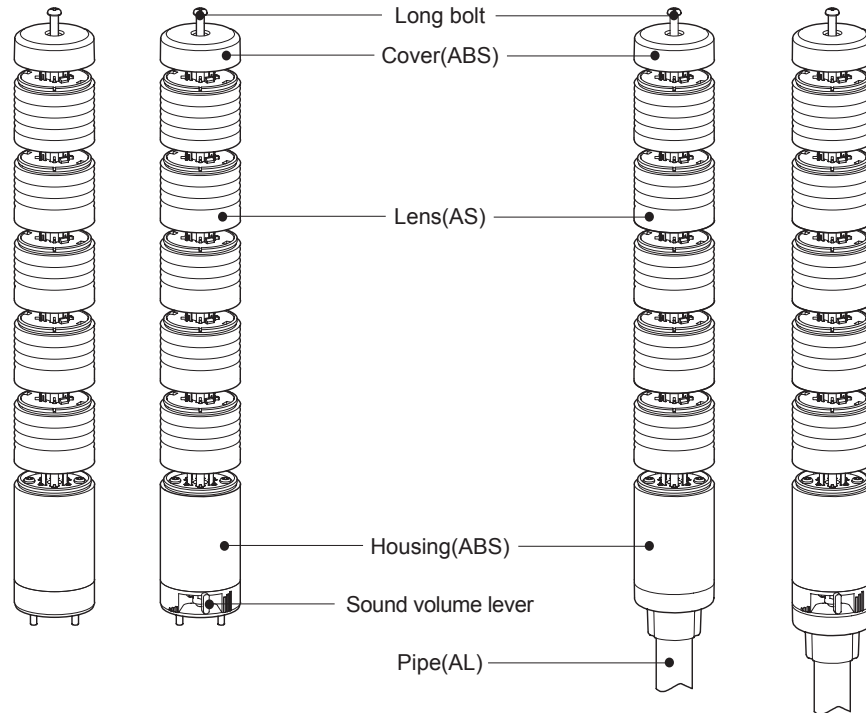

How to Change Lens Kit

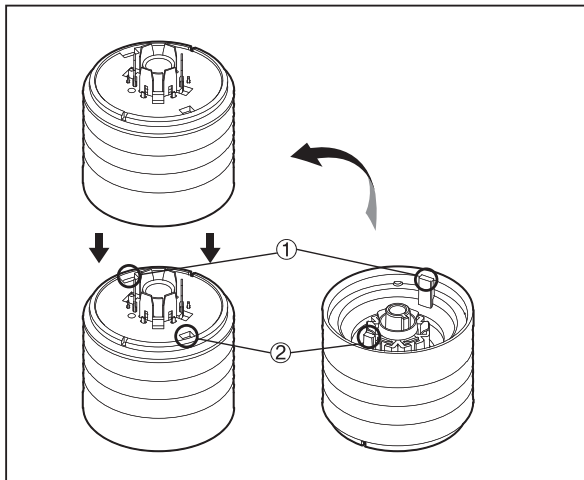

Please ensure that contact points of the two lens kits are aligned together prior to assembly. Slowly combine the color LED lens units together at the contact points shown the image above (①,②). Ensure the upper and lower contacts are seamlessly coupled and then firmly press the units together to complete assembly.

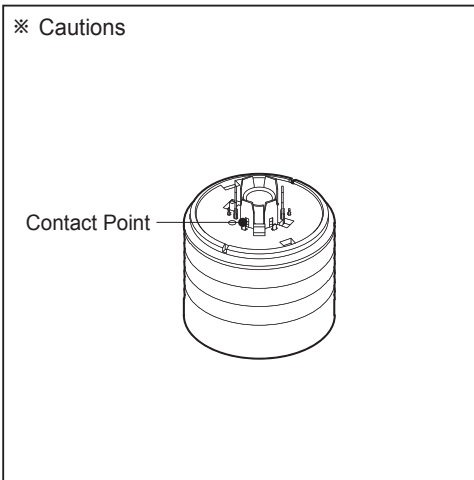

※ Cautions

Lens modules are connected through contact point of each module. In case the contact point is damaged, it may cause a contact failure.

Installation Environment and Protection Rating

- This product is designed for indoor use with protection rating of IP65(Standard type) or IP54(Buzzer type).
- If the product is installed in locations that subject it to excessive dust or water other than the designated IP protection rating indicated(IP65), it may cause malfunction or damage to the product.
- For further information, please visit our website (<http://www.qlight.com>).

Buzzer Sound Volume Adjustment Instructions

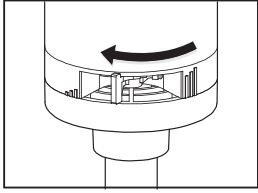

Buzzer volume is reduced by sliding the volume control lever to the left as shown in the diagram to the left.
(Min. 65±4dB/m)

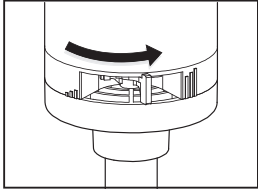

Raise/ increase the buzzer volume by sliding the control lever to the right as shown in the diagram to the left.
(Max. 85±4dB/m)

■ 2 Sound Buzzer Type

- Buzzer type model with 2 different sounds of long beeping sound and short beeping sound is available upon request.

Mounting Hole Specifications

■ STG40ML/ STG50ML - Direct Mounting Type Model

- ① Machine holes on the mounting surface referring to the diagram below.

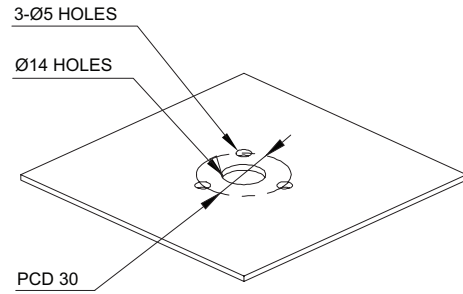

STG40/ 50ML

- ② First, remove the flange nuts from bolts and place the product through the mounting surface holes.
- ③ Fasten the flange nuts on the opposite side of the mounting surface until the product is tightened securely.

Mounting Accessories (Sold Separately)

- Please refer to the dimensions below for installation of mounting brackets.

■ STG40ML/ STG50ML - Direct Mounting Type Model

		Dimensions	
STG40 series STG50 series	<p>TWS45</p>	<p>TWA45</p>	

■ STG40L/ STG50L - Pole Mounting Type Model

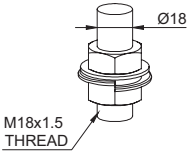
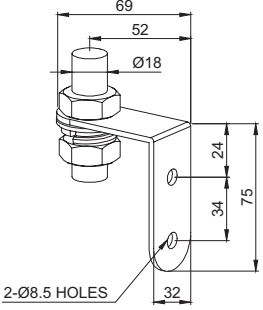
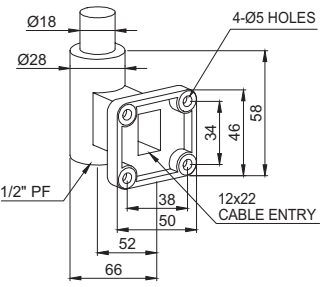
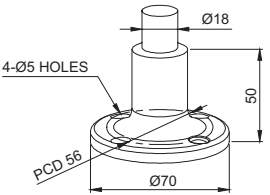
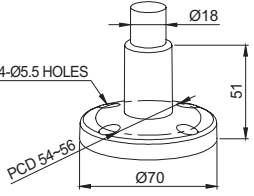
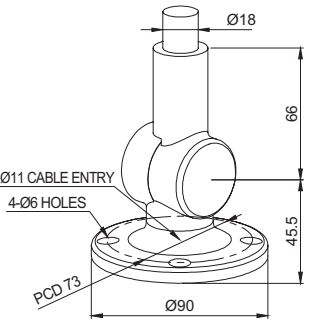
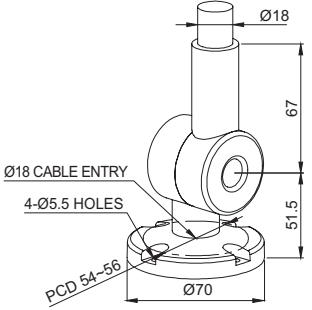
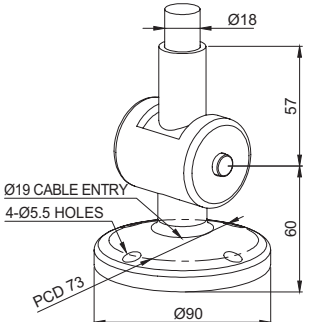
		Dimensions	
STG40 series STG50 series	 <p>M18x1.5 THREAD</p> <p>Ø18</p> <p>18mm SCREW & NUT</p>	 <p>69 52 Ø18 24 34 75 32 2-Ø8.5 HOLES</p> <p>LB18</p>	
	 <p>Ø18 Ø28 4-Ø5 HOLES 1/2" PF 34 46 58 38 50 12x22 CABLE ENTRY 52 66</p> <p>LW18</p>	 <p>Ø18 4-Ø5 HOLES PCD 56 Ø70 50</p> <p>SZ18</p>	
	 <p>Ø18 4-Ø5.5 HOLES PCD 54-56 Ø70 51</p> <p>QZ18</p>	 <p>Ø18 66 Ø11 CABLE ENTRY 4-Ø6 HOLES PCD 73 Ø90 45.5</p> <p>SL18</p>	
	 <p>Ø18 67 Ø18 CABLE ENTRY 4-Ø5.5 HOLES PCD 54-56 Ø70 51.5</p> <p>QL18</p>	 <p>Ø18 57 Ø19 CABLE ENTRY 4-Ø5.5 HOLES PCD 73 Ø90 60</p> <p>QLA18</p>	



Innovation in Alarm & Signal

Product Operation Inquiry / Customer Support +82-55-328-4082

You can expect prompt service if you have exact information such as model name, symptom, telephone number and address.

※ ALL PRODUCT, PRODUCT SPECIFICATIONS AND DATA ARE SUBJECT TO CHANGE WITHOUT NOTICE TO IMPROVE RELIABILITY, FUNCTION OR DESIGN OR OTHERWISE.

Head office : A-412, 579 Kyungin-Ro, Guro-Gu, Seoul, Korea (Postal Code : 08212)

Factory : 185-25, Mukbang-Ro, Sangdong-Myeon, Gimhae-Si, Gyeongsangnam-Do, Korea (Postal Code : 50805)

www.qlight.com

EN-1811A