

**WARRANTY.** The F&F products are covered by a warranty of the 24 months from the date of purchase. Effective only with proof of purchase. Contact your dealer or directly with us. More information how to make a complaint can be found on the website: [www.fif.com.pl/reklamacje](http://www.fif.com.pl/reklamacje)



**Do not dispose of this device in the trash along with other waste!** According to the Law on Waste, electro coming from households free of charge and can give any amount to up to that end point of collection, as well as to store the occasion of the purchase of new equipment (in accordance with the principle of old-for-new, regardless of brand). Electro thrown in the trash or abandoned in nature, pose a threat to the environment and human health.

### Purpose

The MB-GPS-1 transducer, based on the received signal, provides current data for its location:

- \* geographical coordinates (length/width);
- \* data (year/month/day);
- \* time (hour/minutes/seconds);
- \* altitude (meters above the sea level).

### Functioning

The device is equipped with the location module of the GPS (Global Positioning System) and the GLONASS system (Russian: ГЛО-НАСС, Глобальная навигационная спутниковая система, Globalnaja nawigacjonnaja sputnikowaja sistemiema).

The device, based on one of these signals, provides current data for its location: geographical coordinates (length and width), date and time.

If the satellite signal is lost, the device continues the countdown in the internal clock. When the satellite signal is re-established, the internal clock time is synchronized to the received value.



The MB-GPS-1 transducer cannot be used in navigation systems.

### Description of the device

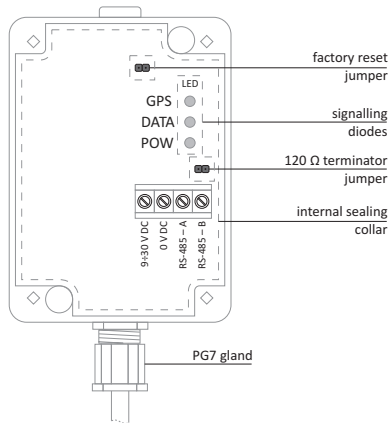

### Diode designations

[GPS]	
ON	GPS/GLONASS signal received correctly
OFF	no GPS/GLONASS signal
[DATA]	
flashing	communication with the module
OFF	no communication
[POW]	
ON	power supply
OFF	no power supply



All elements visible after removing the top cover.

### Default settings

Modbus address	1
speed	9600 bps
parity	none
stop bits	2

### Restore factory settings

To restore the factory settings:

- 1) Turn the device power off.
- 2) Set the jumper to restore factory settings.
- 3) Turn the device power on.
- 4) Remove the jumper to restore factory settings



Leaving the factory settings reset jumper in place will reset the settings after each power-on.

### Technical data

power supply	9÷30 V DC
maximum current consumption	40 mA
port	RS-485
communication protocol	Modbus RTU
working type	SLAVE
communication parameters	
speed (adjustable)	1 200÷115 200 bit/s
data bits	8
stop bits	1/1,5/2
parity	EVEN/ODD/NONE
address	1÷247
power consumption	0.3 W
working temperature	-40÷70°C
terminal	2.5 mm <sup>2</sup> screw terminals
tightening torque	0.4 Nm
dimensions	60×85×35 mm
mounting	surface
protection level	IP65

### CE declaration

F&F Filipowski sp. j. declares that the device is in conformity with the essential requirements of Directive 2014/53/EU of the European Parliament and of the Council of 16 April 2014 on the harmonisation of the laws of the Member States relating to the making available on the market of radio equipment and repealing Directive 1999/5/EC. The CE Declaration of Conformity, along with the references to the standards in relation to which conformity is declared, can be found at [www.fif.com.pl](http://www.fif.com.pl) on the product page.

## Modbus registers

R	reading only
R/W	reading and writing
R/PW	reading and protected writing (writing possible only in configuration mode)



Registers are read with the 0x03 commands and written with the 0x06 command.

Address	Mode	Command description
0x00	R	1 – if GPS/GLONASS signal is correctly received 0 – if there is no signal
0x01	R	Time (in seconds) since GPS/GLONASS signal loss [LSW] (only counts if satellite signal was received at least once)
0x02	R	Time (in seconds) since GPS/GLONASS signal loss [MSW] (only counts if satellite signal was received at least once)
0x10	R	Current UTC time – hours (calculated from the internal RTC clock if there is no satellite signal)
0x11	R	Current UTC time – minutes (calculated from the internal RTC clock if there is no satellite signal)
0x12	R	Current UTC time – seconds (calculated from the internal RTC clock if there is no satellite signal)
0x20	R	Current date – days (calculated from the internal RTC clock if there is no satellite signal)
0x21	R	Current date – months (calculated from the internal RTC clock if there is no satellite signal)
0x22	R	Current date – years (calculated from the internal RTC clock if there is no satellite signal)
0x23	R	Current date – day of the week [1-7] (calculated from the internal RTC clock if there is no satellite signal)

Address	Mode	Command description
0x30	R	Last time received from GPS/GLONASS – hours (does not change if there is no satellite signal)
0x31	R	Last time received from GPS/GLONASS – minutes (does not change if there is no satellite signal)
0x32	R	Last time received from GPS/GLONASS – seconds (does not change if there is no satellite signal)
0x40	R	Last date received from GPS/GLONASS – days (does not change if there is no satellite signal)
0x41	R	Last date received from GPS/GLONASS – months (does not change if there is no satellite signal)
0x42	R	Last date received from GPS/GLONASS – years (does not change if there is no satellite signal)
0x43	R	Last date received from GPS/GLONASS – day (does not change if there is no satellite signal)
0x50	R	Latitude ['N' or 'S']
0x51	R	Latitude – degrees
0x52	R	Latitude – minutes
0x53	R	Latitude – seconds
0x54	R	Latitude – decimal degrees [DD] (Float [LSW])
0x55	R	Latitude – decimal degrees [DD] (Float [MSW])
0x60	R	Longitude ['E' or 'W']
0x61	R	Longitude – degrees
0x62	R	Longitude – minutes
0x63	R	Longitude – seconds

Address	Mode	Command description
0x64	R	Longitude – decimal degrees [DD] (Float [LSW])
0x65	R	Longitude – decimal degrees [DD] (Float [MSW])
0x100	R/W	Modbus address (1÷247)
0x101	R/W	Transmission rate: 0 – 1 200 bps 1 – 2 400 bps 2 – 4 800 bps 3 – 9 600 bps 4 – 19 200 bps 5 – 38 400 bps 6 – 57 600 bps 7 – 115 200 bps
0x102	R/W	Parity control: 0 – BRAK 1 – EVEN 2 – ODD
0x103	R/W	Number of stop bits: 0 – 1 bit 1 – 1,5 bits 2 – 2 bits
0x104	R/W	Entering 1 restores the default configuration
0x400	R	Operating time – seconds [LSW]
0x401	R	Operating time – seconds [MSW]

Address	Mode	Command description
0x405	R	Program version
0x406÷0x40B	R	Device identifier – string „F&F_MB-GPS-1“
0x406	R	„F&“
0x407	R	„F_“
0x408	R	„MB“
0x409	R	„-G“
0x40A	R	„PS“
0x40B	R	„-1“
0x40F	R	Jumper condition restoring factory settings (1 – on, 0 – off)