

# DATA SHEET

## **TDA7072A/AT** Single BTL power driver

Objective specification  
File under Integrated circuits, IC01

July 1994

## Single BTL power driver

## TDA7072A/AT

## FEATURES

- No external components
- Very high slew rate
- Single power supply
- Short-circuit proof
- High output current (0.6 A)
- Wide supply voltage range
- Low output offset voltage
- Suited for handling PWM signals up to 176 kHz
- ESD protected on all pins

## GENERAL DESCRIPTION

The TDA7072A/AT are single power driver circuits in a BTL configuration, intended for use as a power driver for servo systems with a single supply. They are specially designed for compact disc players and are capable of driving focus, tracking, sled functions and spindle motors.

## Missing Current Limiter (MCL)

A MCL protection circuit is built-in. The MCL circuit is activated when the difference in current between the output terminal of each amplifier exceeds 100 mA (typical 300 mA). This level of 100 mA allows for headphone applications (single-ended).

## QUICK REFERENCE DATA

SYMBOL	PARAMETER	CONDITIONS	MIN.	TYP.	MAX.	UNIT
$V_P$	positive supply voltage range		3.0	5.0	18	V
$G_V$	internal voltage gain		32.5	33.5	34.5	dB
$I_P$	total quiescent current	$V_P = 5\text{ V}; R_L = \infty$	–	4	8	mA
SR	slew rate		–	12	–	V/ $\mu$ s
$I_O$	output current		–	–	0.6	A
$I_{\text{bias}}$	input bias current		–	100	300	nA
$f_{\text{co}}$	cut-off frequency	–3 dB	–	1.5	–	MHz

## ORDERING INFORMATION

EXTENDED TYPE NUMBER	PACKAGE			
	PINS	PIN POSITION	MATERIAL	CODE
TDA7072A	8	DIL	plastic	SOT97 <sup>(1)</sup>
TDA7072AT	8	mini-pack	plastic	SOT96A <sup>(2)</sup>

## Notes

1. SOT97-1; 1996 September 10.
2. SOT96-1; 1996 September 10.

Single BTL power driver

TDA7072A/AT

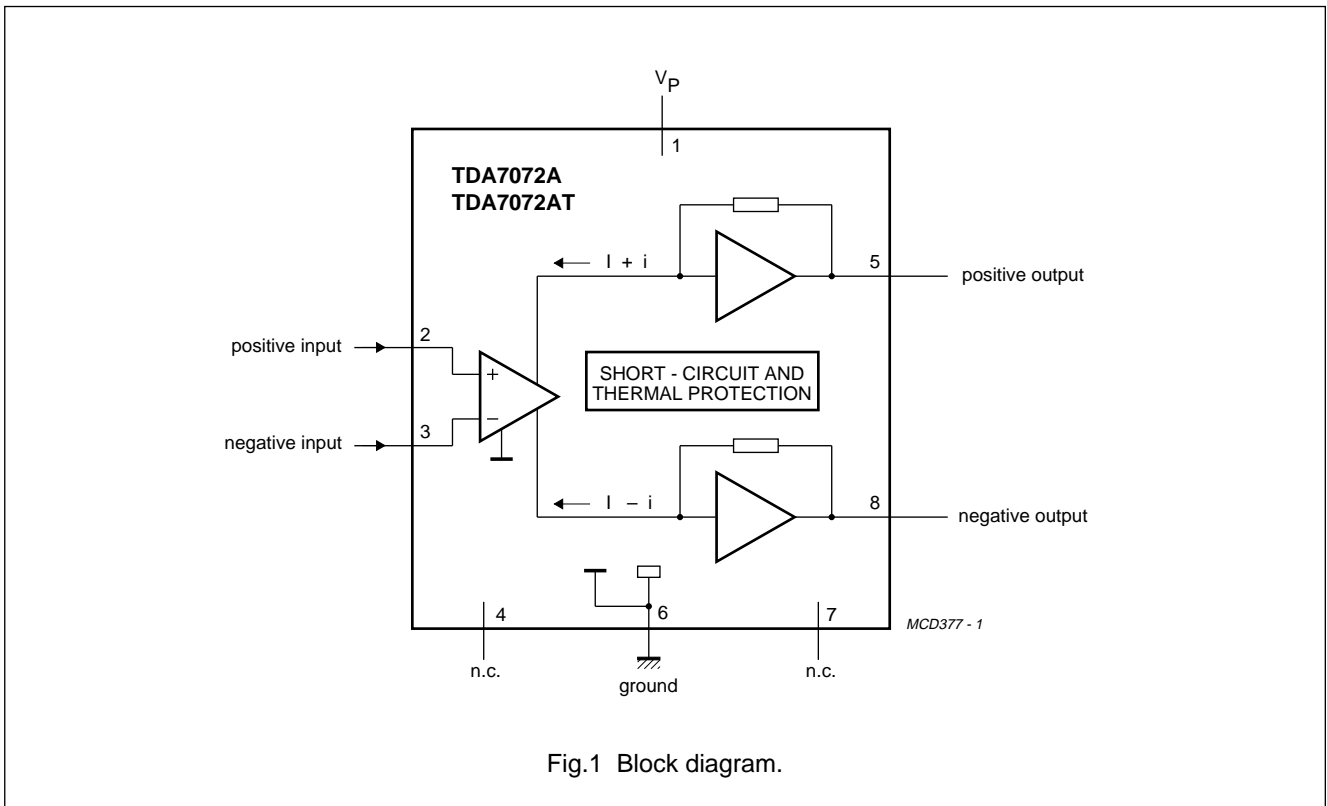

**PINNING**

SYMBOL	PIN	DESCRIPTION
V <sub>P</sub>	1	positive supply voltage
IN+	2	positive input
IN-	3	negative input
n.c.	4	not connected
OUT+	5	positive output
GND	6	ground
n.c.	7	not connected
OUT-	8	negative output

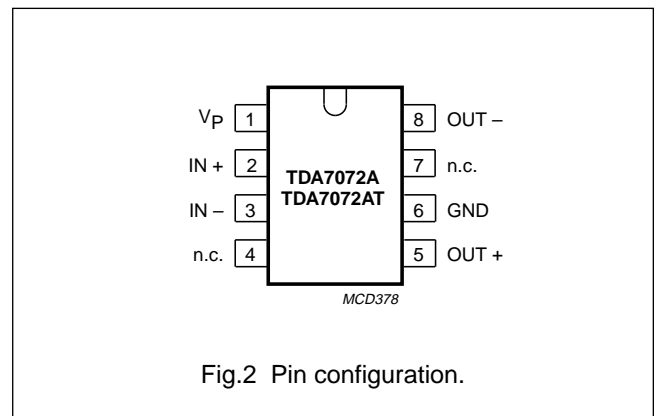

## Single BTL power driver

## TDA7072A/AT

**FUNCTIONAL DESCRIPTION**

The TDA7072A/AT are single power driver circuits in a BTL configuration, intended for use as a power driver for servo systems with a single supply. They are particular designed for compact disc players and are capable of driving focus, tracking, sled functions and spindle motors.

Because of the BTL configuration, the devices can supply a bi-directional DC current in the load, with only a single supply voltage. The voltage gain is fixed by internal

feedback at 33.5 dB and the devices operate in a wide supply voltage range (3 to 18 V). The devices can supply a maximum output current of 0.6 A. The outputs can be short-circuited over the load, to the supply and to ground at all input conditions. The differential inputs can handle common mode input voltages from ground level up to ( $V_P - 2.2$  V). The devices have a very high slew rate. Due to the large bandwidth, they can handle PWM signals up to 176 kHz.

**LIMITING VALUES**

In accordance with the Absolute Maximum System (IEC 134).

SYMBOL	PARAMETER	CONDITIONS	MIN.	MAX.	UNIT
$V_P$	positive supply voltage range		–	18	V
$I_{ORM}$	repetitive peak output current		–	1	A
$I_{OSM}$	non repetitive peak output current		–	1.5	A
$P_{tot}$	total power dissipation	$T_{amb} < 25$ °C			
	TDA7072A		–	1.25	W
	TDA7072AT	–	0.54	W	
$T_{stg}$	storage temperature range		–55	+150	°C
$T_{vj}$	virtual junction temperature		–	+150	°C
$T_{sc}$	short-circuit time	see note	–	1	hr

**Note to the limiting values**

The outputs can be short-circuited over the load, to the supply and to ground at all input conditions.

**THERMAL RESISTANCE**

SYMBOL	PARAMETER	THERMAL RESISTANCE
$R_{th\ j-a}$	from junction to ambient in free air	
	TDA7072A	100 K/W
	TDA7072AT	155 K/W

**Note to the thermal resistance**

TDA7072A:  $V_P = 5$  V;  $R_L = 8$   $\Omega$ ; The typical voltage swing = 5.8 V and  $V_{loss}$  is 2.1 V therefore  $I_O = 0.36$  A and  $P_{tot} = 0.76$  W;  $T_{amb\ (max)} = 150 - 0.76 \times 100 = 74$  °C

TDA7072AT:  $V_P = 5$  V;  $R_L = 16$  typical voltage swing = 5.8 V and  $V_{loss}$  is 2.1 V therefore  $I_O = 0.18$  A and  $P_{tot} = 0.38$  W;  $T_{amb\ (max)} = 150 - 0.38 \times 155 = 91$  °C

## Single BTL power driver

## TDA7072A/AT

**CHARACTERISTICS**

$V_P = 5\text{ V}$ ;  $f = 1\text{ kHz}$ ;  $T_{\text{amb}} = 25\text{ °C}$ ; unless otherwise specified (see Fig.3>). TDA7072A:  $R_L = 8\ \Omega$ ;  
TDA7072AT:  $R_L = 16\ \Omega$ .

SYMBOL	PARAMETER	CONDITIONS	MIN.	TYP.	MAX.	UNIT
$V_P$	positive supply voltage range		3.0	5.0	18	V
$I_{ORM}$	repetitive peak output current		–	–	0.6	A
$I_P$	total quiescent current	$R_L = \infty$ ; note 1	–	4	8	mA
$\Delta V_{OUT}$	output voltage swing	note 2	5.2	5.8	–	V
THD	total harmonic distortion	$V_{OUT} = 1\text{ V (RMS)}$				
	TDA7072A		–	0.3	–	%
	TDA7072AT		–	0.1	–	%
$G_V$	voltage gain		32.5	33.5	34.5	dB
$V_{no(rms)}$	noise output voltage (RMS value)	note 3	–	75	150	$\mu\text{V}$
B	bandwidth		–	–	1.5	MHz
SVRR	supply voltage ripple rejection	note 4	40	55	–	dB
$ \Delta V_{5-8} $	DC output offset voltage	$R_S = 500\ \Omega$	–	–	100	mV
$V_{I(CM)}$	DC common mode voltage range	note 5	0	–	2.8	V
CMRR	DC common mode rejection ratio	note 6	–	100	–	dB
$Z_I$	input impedance		–	100	–	k $\Omega$
$I_{bias}$	input bias current		–	100	300	nA
SR	slew rate		–	12	–	V/ $\mu\text{s}$

**Notes to the characteristics**

1. With a load connected to the outputs the quiescent current will increase, the maximum value of this increase being equal to the DC output offset voltage divided by  $R_L$ .
2. The output voltage swing is typically limited to  $2 \times (V_P - 2.1\text{ V})$  (see Fig.4).
3. The noise output voltage (RMS value), unweighted (20 Hz to 20 kHz) is measured with  $R_S = 500\ \Omega$ .
4. The ripple rejection is measured with  $R_S = 0\ \Omega$  and  $f = 100\text{ Hz}$  to  $10\text{ kHz}$ . The ripple voltage of 200 mV (RMS value) is applied to the positive supply rail.
5. The DC common mode voltage range is limited to  $(V_P - 2.2\text{ V})$ .
6. The common mode rejection ratio is measured at  $V_{ref} = 1.4\text{ V}$ ,  $V_{I(CM)} = 200\text{ mV}$  and  $f = 1\text{ kHz}$ .

Single BTL power driver

TDA7072A/AT

APPLICATION INFORMATION

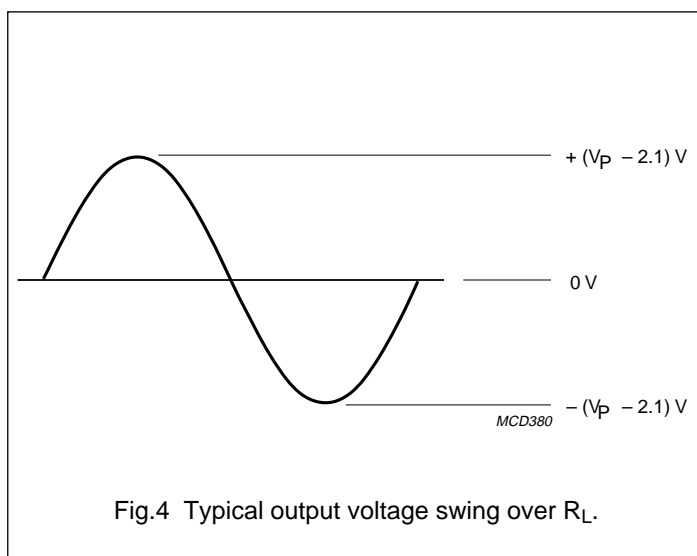
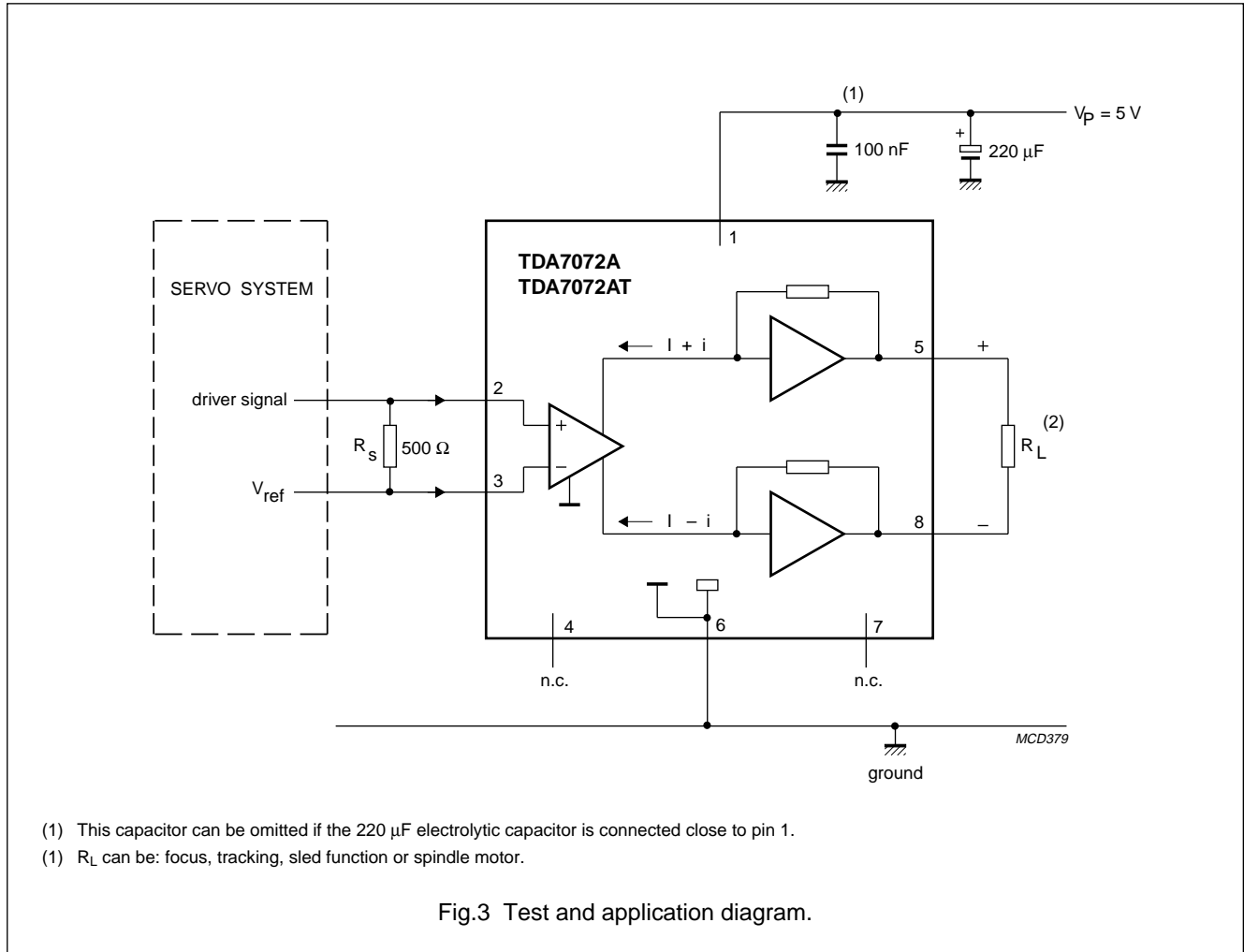

Single BTL power driver

TDA7072A/AT

PACKAGE OUTLINES

DIP8: plastic dual in-line package; 8 leads (300 mil)

SOT97-1

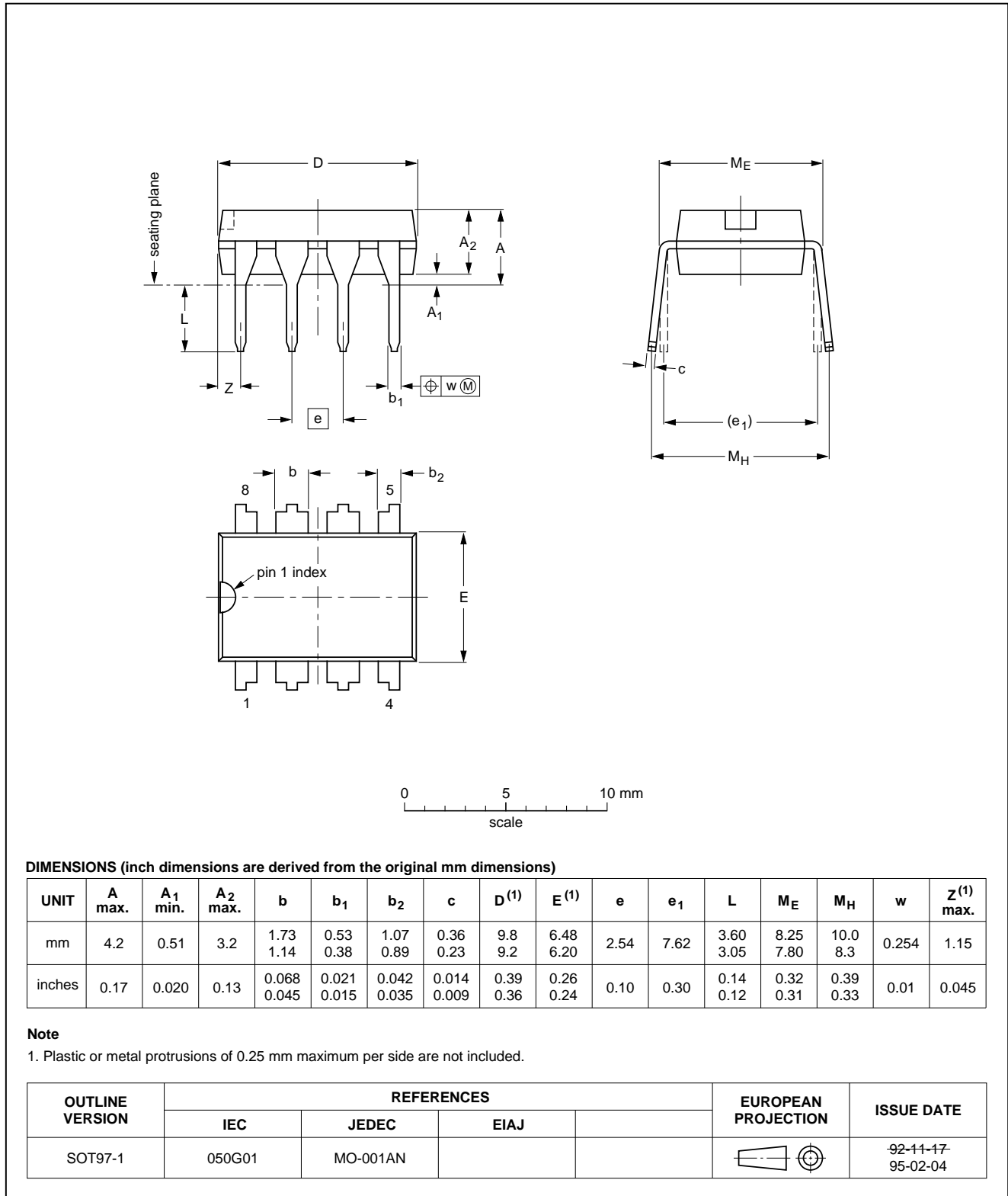

Single BTL power driver

TDA7072A/AT

SO8: plastic small outline package; 8 leads; body width 3.9 mm

SOT96-1

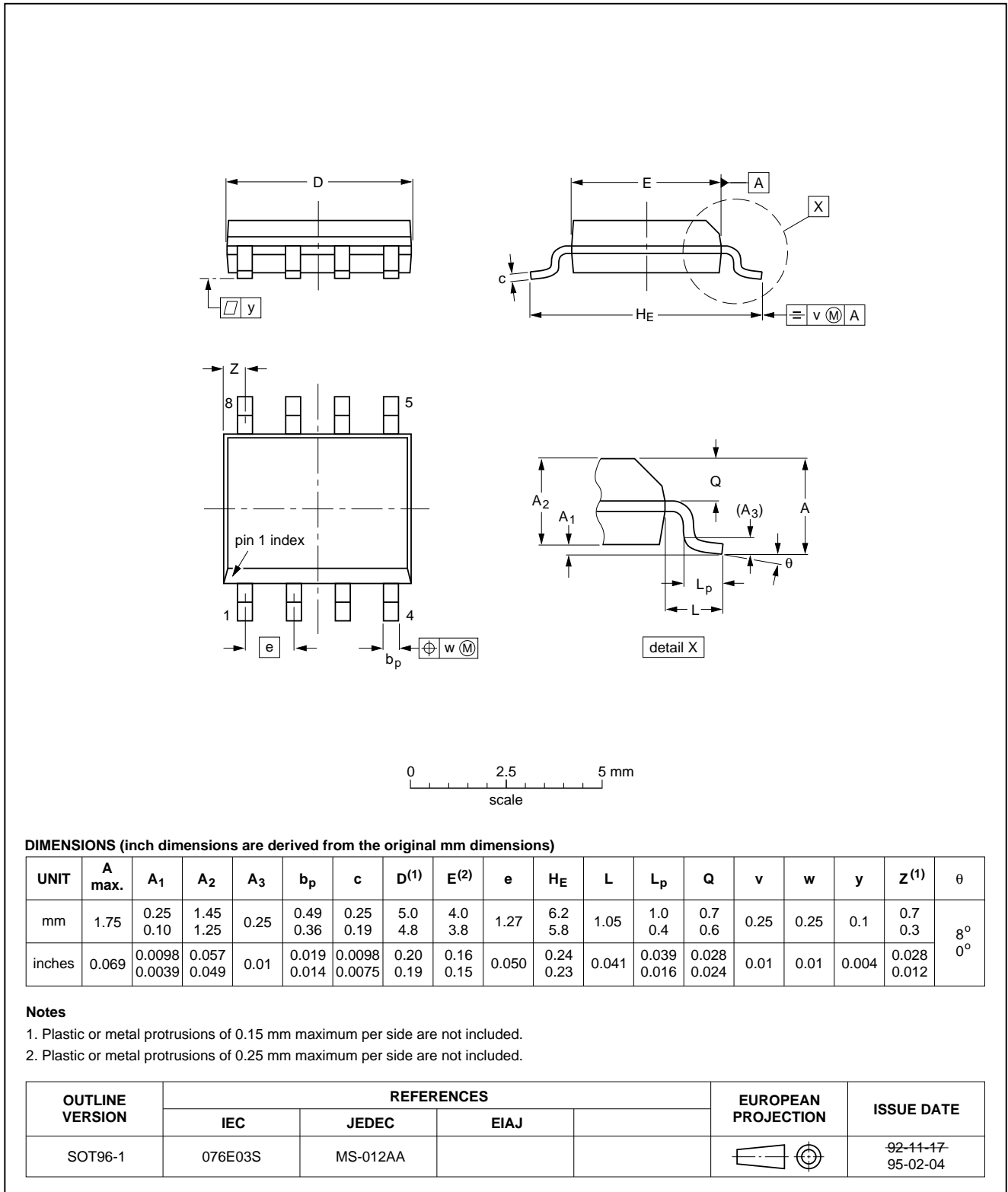



## Single BTL power driver

## TDA7072A/AT

### SOLDERING

#### Introduction

There is no soldering method that is ideal for all IC packages. Wave soldering is often preferred when through-hole and surface mounted components are mixed on one printed-circuit board. However, wave soldering is not always suitable for surface mounted ICs, or for printed-circuits with high population densities. In these situations reflow soldering is often used.

This text gives a very brief insight to a complex technology. A more in-depth account of soldering ICs can be found in our "IC Package Databook" (order code 9398 652 90011).

#### DIP

##### SOLDERING BY DIPPING OR BY WAVE

The maximum permissible temperature of the solder is 260 °C; solder at this temperature must not be in contact with the joint for more than 5 seconds. The total contact time of successive solder waves must not exceed 5 seconds.

The device may be mounted up to the seating plane, but the temperature of the plastic body must not exceed the specified maximum storage temperature ( $T_{stg\ max}$ ). If the printed-circuit board has been pre-heated, forced cooling may be necessary immediately after soldering to keep the temperature within the permissible limit.

##### REPAIRING SOLDERED JOINTS

Apply a low voltage soldering iron (less than 24 V) to the lead(s) of the package, below the seating plane or not more than 2 mm above it. If the temperature of the soldering iron bit is less than 300 °C it may remain in contact for up to 10 seconds. If the bit temperature is between 300 and 400 °C, contact may be up to 5 seconds.

#### SO

##### REFLOW SOLDERING

Reflow soldering techniques are suitable for all SO packages.

Reflow soldering requires solder paste (a suspension of fine solder particles, flux and binding agent) to be applied to the printed-circuit board by screen printing, stencilling or pressure-syringe dispensing before package placement.

Several techniques exist for reflowing; for example, thermal conduction by heated belt. Dwell times vary between 50 and 300 seconds depending on heating method. Typical reflow temperatures range from 215 to 250 °C.

Preheating is necessary to dry the paste and evaporate the binding agent. Preheating duration: 45 minutes at 45 °C.

##### WAVE SOLDERING

Wave soldering techniques can be used for all SO packages if the following conditions are observed:

- A double-wave (a turbulent wave with high upward pressure followed by a smooth laminar wave) soldering technique should be used.
- The longitudinal axis of the package footprint must be parallel to the solder flow.
- The package footprint must incorporate solder thieves at the downstream end.

During placement and before soldering, the package must be fixed with a droplet of adhesive. The adhesive can be applied by screen printing, pin transfer or syringe dispensing. The package can be soldered after the adhesive is cured.

Maximum permissible solder temperature is 260 °C, and maximum duration of package immersion in solder is 10 seconds, if cooled to less than 150 °C within 6 seconds. Typical dwell time is 4 seconds at 250 °C.

A mildly-activated flux will eliminate the need for removal of corrosive residues in most applications.

##### REPAIRING SOLDERED JOINTS

Fix the component by first soldering two diagonally-opposite end leads. Use only a low voltage soldering iron (less than 24 V) applied to the flat part of the lead. Contact time must be limited to 10 seconds at up to 300 °C. When using a dedicated tool, all other leads can be soldered in one operation within 2 to 5 seconds between 270 and 320 °C.

## Single BTL power driver

## TDA7072A/AT

**DEFINITIONS**

<b>Data sheet status</b>	
Objective specification	This data sheet contains target or goal specifications for product development.
Preliminary specification	This data sheet contains preliminary data; supplementary data may be published later.
Product specification	This data sheet contains final product specifications.
<b>Limiting values</b>	
Limiting values given are in accordance with the Absolute Maximum Rating System (IEC 134). Stress above one or more of the limiting values may cause permanent damage to the device. These are stress ratings only and operation of the device at these or at any other conditions above those given in the Characteristics sections of the specification is not implied. Exposure to limiting values for extended periods may affect device reliability.	
<b>Application information</b>	
Where application information is given, it is advisory and does not form part of the specification.	

**LIFE SUPPORT APPLICATIONS**

These products are not designed for use in life support appliances, devices, or systems where malfunction of these products can reasonably be expected to result in personal injury. Philips customers using or selling these products for use in such applications do so at their own risk and agree to fully indemnify Philips for any damages resulting from such improper use or sale.